



# Type 400

## General Service Pressure Regulator

Reliable, all purpose air regulation

The Control Air Type 400 is a general purpose regulator designed to provide reliable performance under variable operating conditions. This quality unit is ideal as an economical alternative for control of industrial process applications. The regulation characteristics of the Type 400 have been proven to be superior to comparable competitive units. Durable materials and corrosion resistant construction provide reliable operation in harsh industrial environments.

### Features

- **Stable Output and Reliability** Consistently meets control requirements under changing operating conditions
- **Corrosion Resistant Construction** Die-cast housings are finished with irridite and epoxy paint
- **Low Droop at High Flow Levels** Aspirator design helps maintain set pressure and minimize "droop" at higher flow levels
- **High Quality Level** Each regulator receives a pressure, leak and flow test at the factory prior to shipment
- **Low Cost** This economical unit is ideal for high volume OEM applications

### Specifications

<b>Flow Capacity</b>	20 SCFM (570 NI/min) at 100 psig (6.8 BAR) supply - 20 psig (1.4 BAR) outlet
<b>Exhaust Capacity</b>	0.1 SCFM (2.8 NI/min)-downstream pressure 5 psig (0.3 BAR) above set point
<b>Sensitivity</b>	1" (2.5 cm) of water
<b>Effect of Supply Pressure Variation</b>	Less than 0.2 psig (0.01 BAR) for 25 psi (1.7 BAR) change
<b>Max. Supply Pressure</b>	250 psig (17 BAR)
<b>Air Consumption</b>	Less than 6 SCFH (170 NI/min)
<b>Output Range</b>	0-10 psig (0-0.7 BAR), 0-30 psig (0-2 BAR), 0-60 psig (0-4 BAR), 0-120 psig (0-8 BAR)
<b>Port Size</b>	1/4" NPT
<b>Mounting</b>	Pipe or panel
<b>Materials</b>	Body: Diecast aluminum alloy Diaphragm: Nitrile elastomer and nylon fabric Trim: Brass, zinc plated steel, acetal
<b>Weight</b>	0.84 lb (0.38 kg)
<b>Temperature Limits</b>	0° to 160°F (-18° to 71°C)



# Type 400 General Service Pressure Regulator

## Dimensions

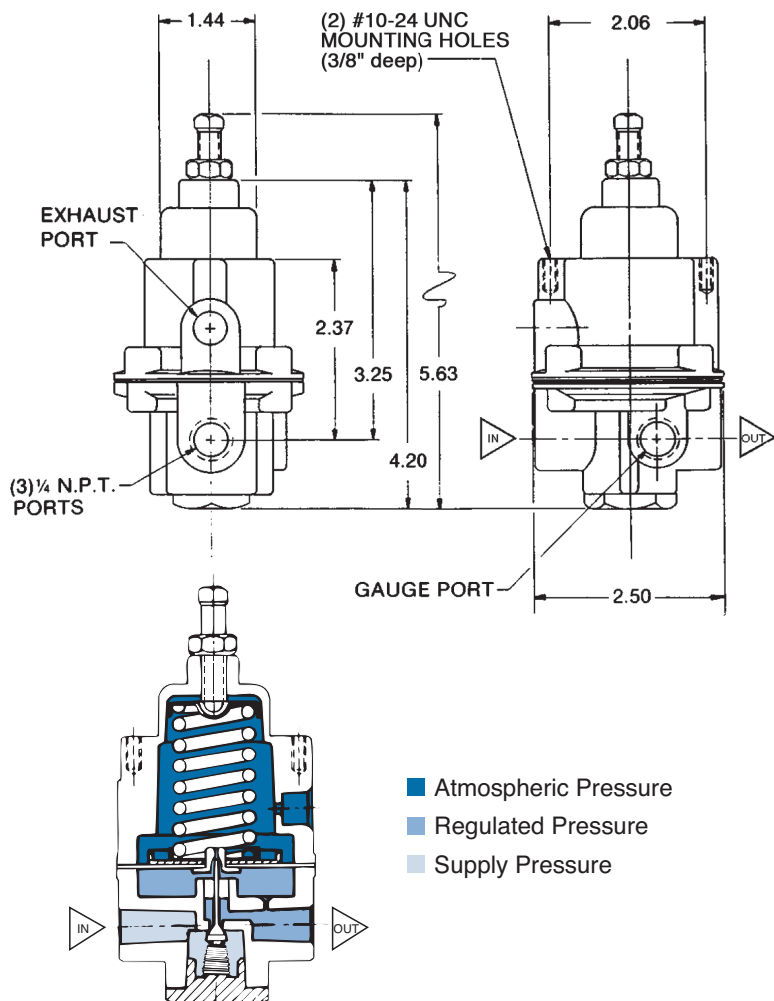

## Ordering

Type	Port Size (NPT)	Output Range (psi)	Output Range (BAR)
400-BD	1/4"	0-10	0-0.7
400-BA	1/4"	0-30	0-2
400-BB	1/4"	0-60	0-4
400-BC	1/4"	0-120	0-8

## Options

Add proper letter at end of model number.

- J - Low Temperature:** Temperature range -40° to 125°F (-40° to 81°C)
- K - Knob:** To replace square head adjust screw
- N - Non-Relieving:** For constant flow or downstream pressure relief applications
- E - Tapped Exhaust:** Allows captured exhaust 1/4" NPT port
- T - Tamperproof Cover:** Prevents casual adjustment of output pressure
- S - Stainless Steel Adjust Screw:** Hex head stainless steel adjust screw for maximum corrosion resistance
- V - Viton Elastomers:** Used where elements in the supply air are particularly destructive to standard Buna-N pindle and diaphragm material
- X - ATEX:** 2014/34/EU

## Accessories

- G - Pressure Gauge:** 2" face, back mounted. When specified with the regulator the correct range will be supplied.

Range	P/N
0-15	446-725-003
0-30	446-725-004
0-60	446-725-001
0-160	446-725-002

- B - Mounting Bracket:** zinc-plated steel bracket for side mounting  
P/N: 446-707-028

## Flow Characteristics

100 psig (6.9 BAR) supply

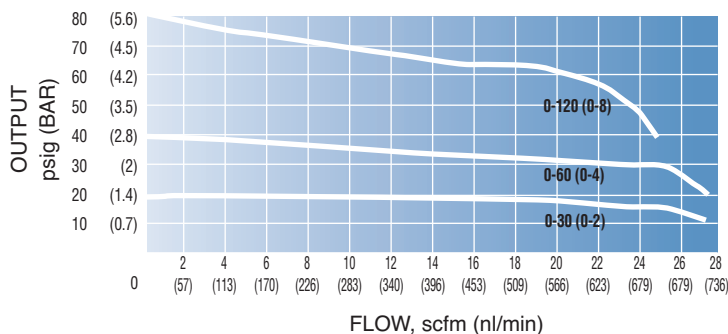

**Warranty** ControlAir, LLC products are warranted to be free from defects in materials and workmanship for a period of eighteen months from the date of sale, provided said products are used according to ControlAir, LLC recommended usages. ControlAir, LLC's liability is limited to the repair, purchase price refund, or replacement in kind, at ControlAir, LLC's sole option, of any products proved defective. ControlAir, LLC reserves the right to discontinue manufacture of any products or change products materials, designs or specifications without notice. Note: ControlAir does not assume responsibility for the selection, use, or maintenance of any product. Responsibility for the proper selection, use, and maintenance of any ControlAir product remains solely with the purchaser and end user. Drawing downloads available at [www.controlair.com](http://www.controlair.com)



An ISO 9001:2015 Registered Company

PAN 441-625-004 12/19