

Flange for instrumentation with threaded or socket welding connections.

Type A : Threaded connections ANSI B1.20.1 NPT

Type B : Socket welding SW

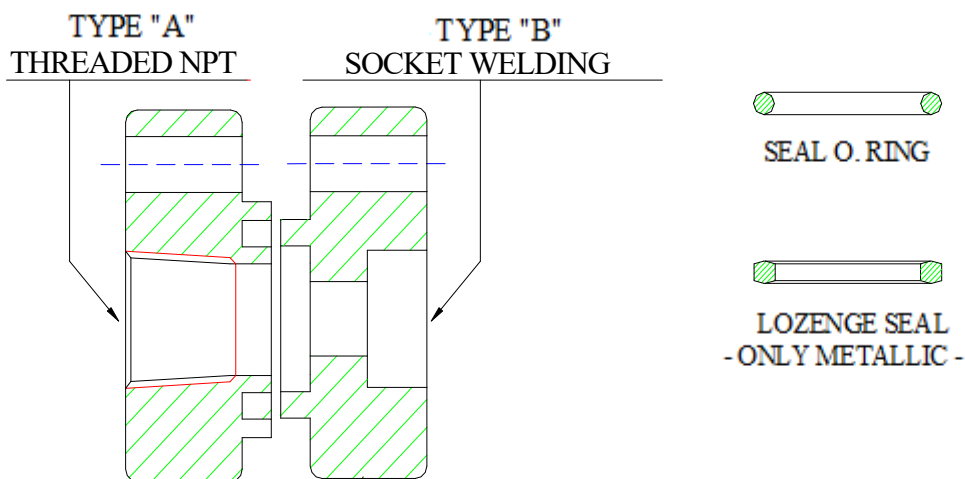
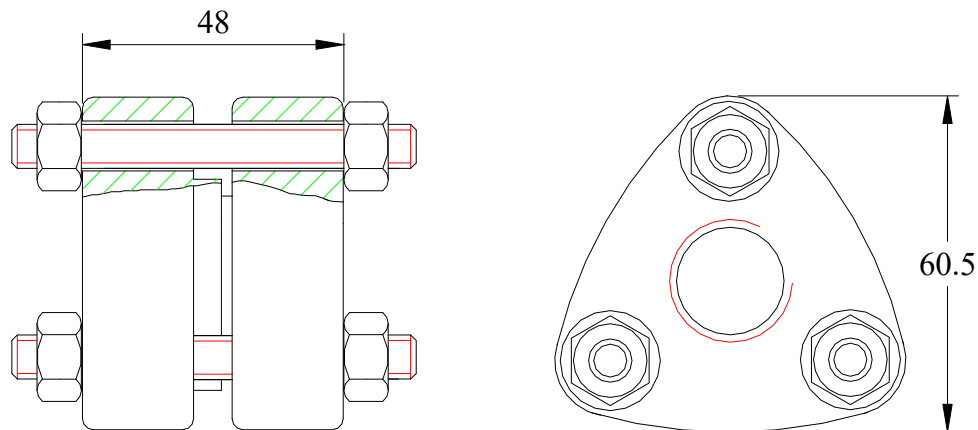

Model	Process connections	DN Size	Material
FT/A/4/C	Threaded NPT ANSI B1.20.1	1/4"	A105
FT/A/2/C	Threaded NPT ANSI B1.20.1	1/2"	A105
FT/A/4/S	Threaded NPT ANSI B1.20.1	1/4"	AISI 316L
FT/A/2/S	Threaded NPT ANSI B1.20.1	1/2"	AISI 316L
FT/B/4/C	Socket welding SW	1/4"	A105
FT/B/2/C	Socket welding SW	1/2"	A105
FT/B/4/S	Socket welding SW	1/4"	AISI 316L
FT/B/2/S	Socket welding SW	1/2"	AISI 316L

S = AISI 316L - C = Carbon Steel