

DATA SHEET



KFA2

4-wire TDR-Sensor with single rod, wire rope or coaxial probe for continuous level measurement and point level detection in liquids and light solids, with analog and switching output.

MEASUREMENT PRINCIPLE

KFA2 uses TDR (Time Domain Reflectometry) technology: low-energy, high-frequency electromagnetic impulses, generated by the sensor's circuitry, are propagated along the probe which is immersed in the liquid or solid to be measured. When these impulses hit the surface of the media, part of the impulse energy is reflected back up the probe to the circuitry which then calculates the level from the time difference between the impulses sent and the impulses reflected. The sensor can output the analysed level as a continuous measurement reading through its analog output, or it can convert the values into freely positionable switching output signals. TDR-Sensors are also known as Guided Radars or Guided Wave Radars (GWR).

APPLICATION AREA

The innovative TDR technology enables direct, precise and highly reliable continuous level measurement as well as point level detection in almost every liquid and solids –independent of changing process conditions (such as density, conductivity, temperature, pressure, vapour and turbulence). KFA2 has almost no installation restrictions - it can be mounted in small tanks, tall and narrow nozzles and it measures precisely even with difficult tank geometries or close to interfering structures. KFA2 is also especially suitable in bypass chambers and stilling wells. It is suitable for all types of process and storage tank applications and has an exceptional performance in media with low dielectric constant (i.e. low reflectivity) such as oils and hydrocarbons.

BENEFITS

- Unmatched price/performance ratio
- Precise continuous level measurement and reliable point level detection combined in one device
- Fully modular probe design, i.e. the probe types are interchangeable without any special tools or welding
- Complete galvanic insulation of device electronics from its inputs/outputs and the tank potential (no problems with electrochemical corrosion protection)
- Highly robust measurement due to 4-wire design and innovative signal analysis and disturbance signal suppression

CONTACT
PandID B.V.

PHONE +31 174 280 371
E-MAIL info@pandid.nl
WEB www.pandid.nl

Figure 1: sensor components

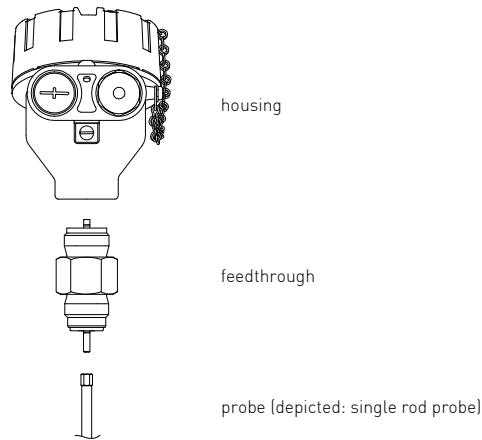
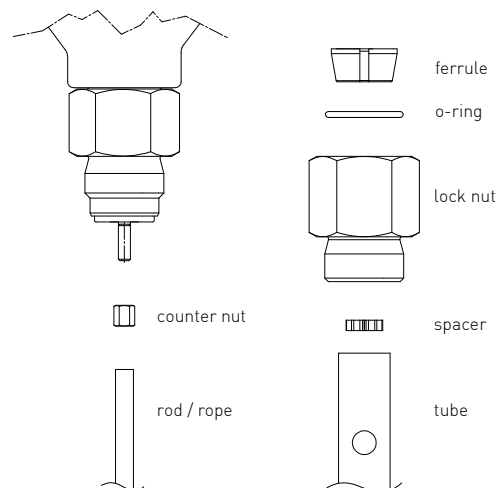

Figure 2: probe type considerations

WIRE ROPE PROBE		
SINGLE ROD PROBE		
COAXIAL PROBE		
PROBE MOUNTING		
tall and narrow nozzles	+	• •
difficult tank or nozzle geometries	+	• • •
close to internal tank structures or tank wall	+	• • • •
probe might move or touch internal tank structures/tank wall	+	• • • • •
liquid spray may touch probe above the liquid surface	+	• • • • •
non-stationary interference targets, e.g. agitator blades	+	• • • • •
measurement readings at the very top or bottom of the tank	+	• • • • •
non-metallic tanks	+	• • • • •
bypass chambers and stilling wells	•	• + •
limited headroom for installation	•	• • • -
tall tanks	•	• • • +
MEDIA CHARACTERISTICS		
bulk solids	-	- • +
measuring low reflectivity liquids [i.e. low dielectric constant]	+	• • • +
viscous, crystallizing, adhesive, coating, or sticky liquids	-	+ • +
fibrous liquids, sludge, slurry, pulp	-	+ • +
liquids containing solid particles	-	+ • +
cleanability of probe is important	-	+ • +

+ = recommended
 • = possible, maybe with configuration and/or mounting adjustments
 - = not recommended

Figure 3: modular probe design



SENSOR COMPONENTS AND PROBE TYPE

KFA2 consists of three major components: housing, feedthrough, and probe. The only components that are exposed to the atmosphere inside the tank are probe and the part of the feedthrough below the hexagon.

The housing contains the sensor's electronics and input/output terminals and has no contact to the tank atmosphere.

The so called feedthrough is mounted into the bottom of the housing and serves two main purposes: its outer threaded metal bushing securely connects the sensor to the tank and its inner components guide the high-frequency measurement signal from the electronics through the tank wall into the tank and back.

The probe is mounted onto the bottom of the feedthrough and gets immersed into the media inside the tank; the high-frequency measurement signal is propagated along the probe.

KFA2 has a flexible modular concept: any probe can be used with any housing since they are joined together by one universal feedthrough.

To meet various application requirements, KFA2 has three different probe types: single rod probe, wire rope probe and coaxial probe.

Single rod and wire rope probe are suitable for a very wide range of applications, but the signal has a wider detection radius around the rod/rope. Thus, they are more responsive for measurement signal disturbances which can be easily overcome by observing a few mounting considerations and making simple configuration adjustments to the sensor. The single rod probe is recommended for installations in liquids and in bypass chambers and stilling wells, which basically act together with the rod as a big coaxial probe. The wire rope probe is recommended for installations in solids, tall tanks and where limited headroom is available.

In the coaxial probe, the high-frequency measurement signal is completely contained within the outer tube. Thus, the coaxial probe is immune against any external conditions and interfering objects outside its tube which could otherwise cause disturbances of the measurement signal. This makes the coaxial probe the ideal solution for a hassle-free 'drop-in anywhere' installation; ensuring reliable measurement under almost any application condition. The concentrated signal within the tube also makes the coaxial probe the ideal choice for measuring low reflectivity liquids (i.e. low dielectric constant) such as oils and hydrocarbons. The coaxial probe is recommended for the use with clean liquids only and cannot be used with solids, viscous, crystallizing, adhesive, coating, or sticky liquids; fibrous liquids, sludge, slurry, pulp; any liquids containing solid particles. Such liquids or solids in general might cause build-up, bridging or clogging inside the coaxial probe.

The probe design of KFA2 is fully modular, i.e. the probe types are interchangeable. The single rod probe actually forms the inner conductor of the coaxial probe: a standard Ø17,2mm or ¾"10S tube is mounted over the single rod probe and tightened with a very simple, yet safe, ferrule/locknut-style connection; similar to the ones widely used in standard tube fittings.

Figure 4: extended temperature option



EXTENDED TEMPERATURE RANGE

KFA2 with single rod and coaxial probes is available with an extended temperature option. A temperature extension is added between the housing and the feedthrough, which reduces the application temperatures (-200°C...+250°C) inside the tank to standard levels that will not damage the sensor electronics inside the housing.

KFA2 must be properly included into the tank insulation to prevent excessive temperatures at the sensor housing due to thermal radiation or convection, as well as prevention of condensate formation. However, the insulation layer should not reach higher than the hexagon nut; the cooling fins of the radiator-style temperature extension have to be outside the insulation in order to function properly. If necessary, adjust the height of the mounting socket or nozzle accordingly.

Figure 5: single rod probe, PTFE coated



PTFE COATED SINGLE ROD PROBE

KFA2 with a single rod probe is available with PTFE coating. This option is very suitable for using the sensor in chemically aggressive and corrosive environments in which the standard stainless steel probe material is not durable enough.

The stainless steel single rod probe is lined with a thick-walled PTFE tube. The bottom of the probe as well as the top of the probe, along with the complete feedthrough section below the hexagon, are sealed off with solid PTFE parts that have several FKM o-rings inside (other materials on request). This design ensures that only PTFE and the selected o-ring materials are exposed to the aggressive atmosphere inside the tank.

The PTFE connection thread offers a very cost effective solution to install KFA2 directly into standard plastic fittings of plastic tanks.

Do not mount the PTFE connection thread into a metal flange.

When installing KFA2 into any type of plastic/rubber/enamel-lined metal tank, the PTFE disk has to be used. Together with the tank liner (usually protruding out the mounting nozzle), the flange disk provides a proper seal on the flange sealing surface. KFA2 is screwed into a metal flange via its standard stainless steel connection thread and then the PTFE disk is attached from the bottom to form the PTFE coated surface of the single rod probe.

Figure 6: probe length and measuring range

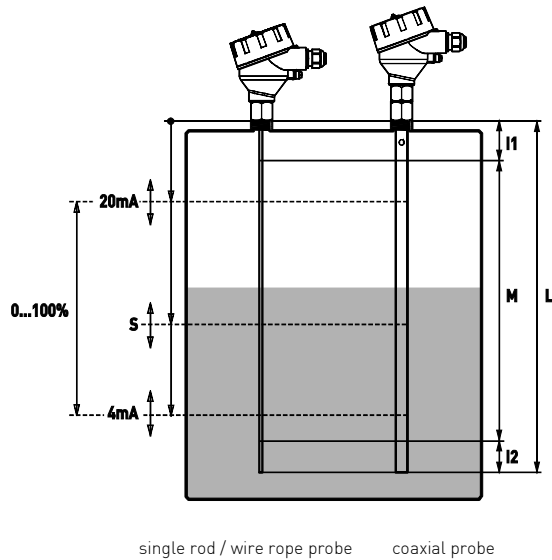

PROBE LENGTH AND MEASURING RANGE

The reference point for definition of the probe length [L] is always the shoulder of the connection thread. The probe length [L] is an important mechanical dimension which is needed to make sure the probe physically fits into the tank at the anticipated mounting location; it is not equal to the actual measuring range [M] of the sensor!

TDR level sensors have small inactive areas at top [I1] and bottom [I2] of the probe. Those are due to the presence of unavoidable signal disturbances at both ends of the probe. In these inactive areas the measurements are non-linear or have reduced accuracy. Therefore, it is not recommended to actually measure level within those inactive areas. Their length depends on the probe type and the reflectivity (i.e. dielectric constant) of the liquid/solid to be measured.

The measuring range [M] of KFA2 extends between the top and bottom inactive areas of the probe; this is the area in which KFA2 will have the specified measurement performance. It is recommended that the maximum and minimum levels to be measured in the tank are actually within the measuring range [M] of the sensor. The span between the lower range value [4mA] and the upper range value [20mA] of the analog current output is equal to 0...100% of your continuous level measurement reading. It is recommended that the span between those two range values stays within the measuring range [M].

The location of the switching point [S] of the switching output can also be freely positioned within the measuring range [M]. Fixed hysteresis or separate upper and lower thresholds can be defined for the switching output.

Figure 7: mounting

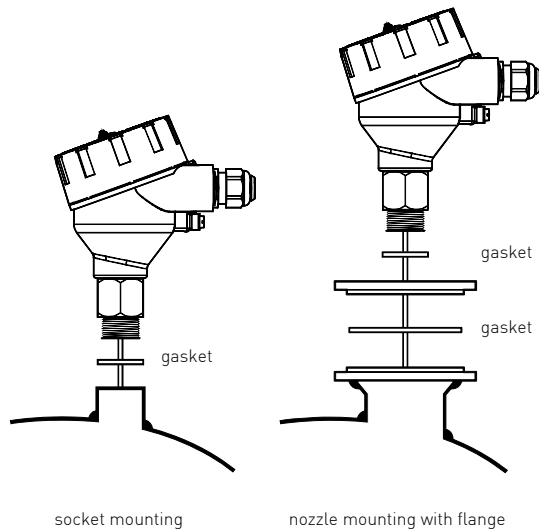

MOUNTING

KFA2 is mounted vertically to the tank via its connection thread, which is screwed directly into a standard threaded tank connection, i.e. weld-in socket, or it can be screwed into a flange, which is then connected to a tank nozzle. The customer has to ensure proper temperature and pressure ratings for his application and has to select the appropriate seal to connect the sensor (KFA2 comes with a Klingersil C-4400 gasket).

KFA2 is very well suited for external mounting into a bypass chamber (with the single rod probe). Thus, KFA2 is also the ideal replacement for chamber-mounted displacers: simply remove the displacer, keep its existing chamber and fit a KFA2 into it. The powerful disturbance signal suppression features of KFA2 ensures easy retrofitting and reliable measurement in almost any existing displacer chamber.

The probes should be installed so that they are not directly impacted by liquids or solids flowing out of the filling inlet. They should neither touch nor sway towards other objects inside the tank or the tank/nozzle walls; e.g. being dragged by agitator swirls. In applications with very strong fluid movements, which can also cause excessive lateral force on the probe, it is recommended to secure the probe to the tank wall or to anchor it at the tank bottom.

Figure 8: mounting considerations

SINGLE ROD / WIRE ROPE PROBE		
COAXIAL PROBE		
nozzle diameter	- ¹	>50mm
nozzle height	-	<300mm
clearance to tank wall or other internal objects	-	>100mm
clearance between probe end and tank bottom	-	>2mm
diameter of bypass chamber / stilling well	- ²	>25mm

- = no restrictions

¹ enough diameter to fit in the coaxial tube (Ø17,2mm)

² enough diameter to fit in the coaxial tube (Ø17,2mm) and enough room around the probe for the liquid to flow in and out of the bypass chamber / stilling well

Single rod and wire rope probes are suitable for a very wide range of applications, but the signal has a wider detection radius around the rod/rope. Thus, it is more responsive for measurement signal disturbances which can be easily overcome by observing a few mounting considerations and making simple configuration adjustments to the sensor; in most cases it is enough to activate and utilize the powerful disturbance signal suppression features of KFA2. However, those work most efficiently on stationary interference targets like tall and narrow nozzles or close-by objects. In case that non-stationary interference targets close to the single rod / wire rope probe, like slowly rotating agitator blades, cause problems with the measurement, it is recommended to use the coaxial probe. In any case, the single rod and wire rope probes should never get in direct contact with the tank/nozzle wall or other objects in the tank.

The coaxial probe does not have restrictions regarding mounting position, tank connection, and proximity to the tank wall or other objects inside the tank.

The coaxial probe is recommended for installing KFA2 into a non-metallic tank or open pit. If that is not possible, single rod or wire rope probes can be used when KFA2 is mounted into at least a DN50 metal flange or screwed into a metal sheet with at least Ø150mm.

Figure 9: electrical connection

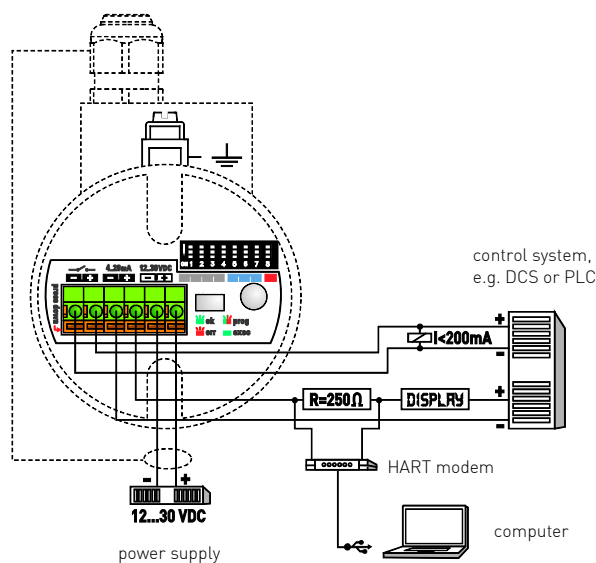

ELECTRICAL CONNECTION

KFA2 is a 4-wire system: a set of 2 wires for the power supply and separate sets of 2 wires for each output.

The wires are connected to the sensor electronic inside the housing via a screwless, cage clamp terminal block for stranded and solid wires 0,5...2mm² / AWG 22...14.

The housing has two cable entries and can be ordered with assembled standard screw plugs and cable glands. Nevertheless, the customer has to confirm the suitability of those cable glands for his specific application requirements and cabling; and replace them when necessary. IP68-rated screw plugs and cable glands have to be properly mounted (with rubber washers underneath) and have to be properly tightened around cable of suitable type and diameter to ensure the IP68 rating of the housing.

KFA2's electronic is galvanically completely insulated from its inputs/outputs and the tank potential; thus avoiding any problems from electrochemical corrosion protection of the tank.

CONFIGURATION

Basic configuration of KFA2 can be done directly on the device via a DIP switch, a single push button and visual feedback from an LED. All settings required to get KFA2 fully operational can be performed directly on the device; or KFA2 can be ordered completely pre-configured.

For greater convenience, remote configuration, and extensive diagnostics a simple EXCEL spread sheet is provided through which the configuration can be done.

A standard HART modem is required for communication between computer and sensor. Communication happens via a digital HART signal that is superimposed onto the analog 4...20mA signal of the current output.

ELECTRICAL SPECIFICATIONS		4-wire system
Output functions	continuous level measurement through analog output and point level detection through switching output	
Analog output (active)	current output 4...20mA	
	the span between the lower range value [4mA] and the upper range value [20mA] is equal to 0...100% of the continuous level measurement reading. It is recommended that the span between those two range values stays within the measuring range [M]	
Total load resistance	<500Ω: HART resistor approx. 250Ω + load resistance approx. 250Ω if the current output is connected to a device with an inner resistance of approx. 250Ω, then there is no additional, external HART resistor necessary. In that case, the HART modem is connected in parallel to the current output wires	
Lower range value	4,0mA (span 0%)	
Upper range value	20,0mA (span 100%)	
Response time	0,5s [default], 2s, 5s (selectable)	
Temperature drift	<0,2mm/K change in ambient temperature	
Switching output DC PNP (active)	NC [default] or NO (short-circuit protected)	
Load current	<200mA	
Signal voltage HIGH	supply voltage - 2V	
Signal voltage LOW	0V...1V	
Response time	<100ms	
Supply voltage	12...30VDC (reverse-polarity protected)	
Current consumption	<50mA at 24VDC (no burden)	
Start-up time	<6s	
Cable terminals	screwless, cage clamp terminal block for stranded and solid wires 0,5...2mm ² / AWG 22...14 the usage of cable end sleeves with insulation collar is not recommended	

MEASUREMENT SPECIFICATIONS		reference condition: dielectric constant [ε _r]=80, water surface, tank Ø1m, DN200 metal flange
Accuracy	±3mm or 0.03% of measured distance, whichever is greatest	
Repeatability	<2mm	
Resolution	<1mm	
Probe type	single rod Ø6mm	max. lateral load: 6Nm = 0.2kg at 3 m
	wire rope Ø4mm, type 7x19 coaxial Ø17,2mm (=NPS ¾", 10S)	max. tensile load: 5kN max. lateral load: 100Nm = 1.67kg at 6 m
Probe length [L]	single rod probe: 100...3.000mm wire rope probe: 1.000...20.000mm	longer length on request
	coaxial probe, standard application temperature: 100...6.000mm coaxial probe, extended application temperature 100...1.000mm can be ordered in 5mm increments the reference point is always the shoulder of the connection thread	
Inactive area top [I1]	single rod probe, ε _r =80: 50mm wire rope probe, ε _r =80: 50mm coaxial probe, ε _r =80: 30mm	single rod probe, ε _r =2: 80mm wire rope probe, ε _r =2: 80mm coaxial probe, ε _r =2: 50mm
Inactive areas bottom [I2]	single rod probe, ε _r =80: 10mm wire rope probe, ε _r =80: 10mm coaxial probe, ε _r =80: 10mm	single rod probe, ε _r =2: 50mm wire rope probe, ε _r =2: 50mm coaxial probe, ε _r =2: 50mm
Measuring range [M]	probe length [L] less both inactive areas at top and bottom [I1 and I2] in this range KFA2 will have the specified measurement performance. It is recommended that the maximum and minimum liquid levels to be measured in the tank are actually within the measuring range [M] of the sensor	
Lower [4mA] and upper [20mA] signal level	[default]: 4mA are set at 10mm above probe end, 20mA are set at 50mm below reference point	
Switching point [S]	freely positionable within the measuring range [M] hysteresis can be set by defining separate upper and lower thresholds; if those are set at the same position, the minimum hysteresis of 3mm applies	
Hysteresis	[default]: switching point is set at 20% of probe length [L], from reference point downwards	

APPLICATION SPECIFICATIONS		continuous level measurement and point level detection in liquids and light solids
Dielectric constant [ϵ_r]	single rod / wire rope probe: >1,8	coaxial probe:>1,4
Conductivity	no restrictions	
Density	no restrictions	
Dynamic viscosity	single rod / wire rope probe: <5.000mPa s = 5.000cP coaxial probe: <500mPa s = 500cP	
Standard application temperature	single rod / wire rope probe:	-40°C...+150°C
	single rod probe PTFE coated:	-15°C...+100°C
	coaxial probe EPDM o-ring:	-40°C...+130°C
	coaxial probe FKM (Viton) o-ring:	-15°C...+150°C
Extended application temperature	NBR o-ring:	-200°C...+250°C
single rod / coaxial probe	FKM (Viton) o-ring:	-150°C...+250°C
Ambient temperature	operation: -25°C...+80°C	storage: -40°C...+85°C
Application pressure	-1bar...40bar, except single rod probe PTFE coated: 0...4bar	
Velocity of level change	<1.000mm/s	
Interface (e.g. oil on top of water)	an oil layer of <70mm thickness on top of water is not detected by the sensor; in this case the sensor will detect only the water level at a slightly lower position than actual. From an oil layer thickness >70mm onwards, the sensor detects the total level, including the oil layer, according to specifications	

MECHANICAL SPECIFICATIONS

Material exposed to tank atmosphere	single rod probe, standard application temperature: 1.4404 / 316L, PEEK single rod probe, ext. temp.: 1.4404 / 316L, PEEK, PTFE, o-ring (see order code) single rod probe PTFE coated: PTFE, o-ring (see order code) wire rope probe: 1.4401 / 316, PEEK coaxial probe, std. temperature: 1.4404 / 316L, PEEK, o-ring (see order code) coaxial probe, ext. temp.: 1.4404 / 316L, PEEK, PTFE, o-ring (see order code) gasket at connection thread: Klingersil C-4400, 2mm thick other materials on request
Materials housing	housing body and cover: <ul style="list-style-type: none"> aluminium alloy EN AC-ALSi9Cu3 (DIN EN 1706), epoxy spray coating (~70µm) other alloys and coatings on request stainless steel 1.4401 / 316 cover o-ring: silicone rubber (Elastosil R 750/50) other o-ring materials on request cover safety chain / screws; cover locking screw; nameplate / rivots: 1.4301 / 304 external earth terminal / screw: tin plated stainless steel 1.4301 / 304
Housing rating	IP68, NEMA6P device cover has to be properly tightened and IP68 screw plugs and cable glands have to be properly mounted (with sealing) and have to be properly tightened around cable of suitable type and diameter the cover has a locking screw (allen key size 1,5mm) and a safety chain to prevent it from falling to the ground after being unscrewed
Cable entries [D2/ D3]	2 cable entries M20x1,5 other dimensions on request
Cable glands / screw plugs	<ul style="list-style-type: none"> [D2]: cable gland, M20x1,5, IP68, nylon PA66, for non-armoured cable Ø5...9mm, with EPDM washer, max. tightening torque 6Nm, wrench size 24mm. For protection during shipment closed with EPDM sealing plug (to be removed for cabling) [D3]: screw plug, IP68, M20x1,5, nylon PA66, with EPDM washer other cable glands / screw plugs on request [D2] and [D3]: protective plugs, PE-LD, not IP68, only for housing protection during shipment, to be replaced by customer
Connection thread [CT]	G¾A or ¾"NPT (wrench size 32mm) other connection threads on request
Weight	aluminium housing (empty): 650g; stainless steel housing (empty): 1.270g electronics: 70g; feedthrough: 220g; single rod probe, 1m: 230g wire rope probe, 1m (no counterweight): 66g; counterweight: 380g coaxial tube (not assembled), 1m: 540g; attachment kit coaxial tube: 130g temperature extension: 900g

DIMENSIONS IN MM

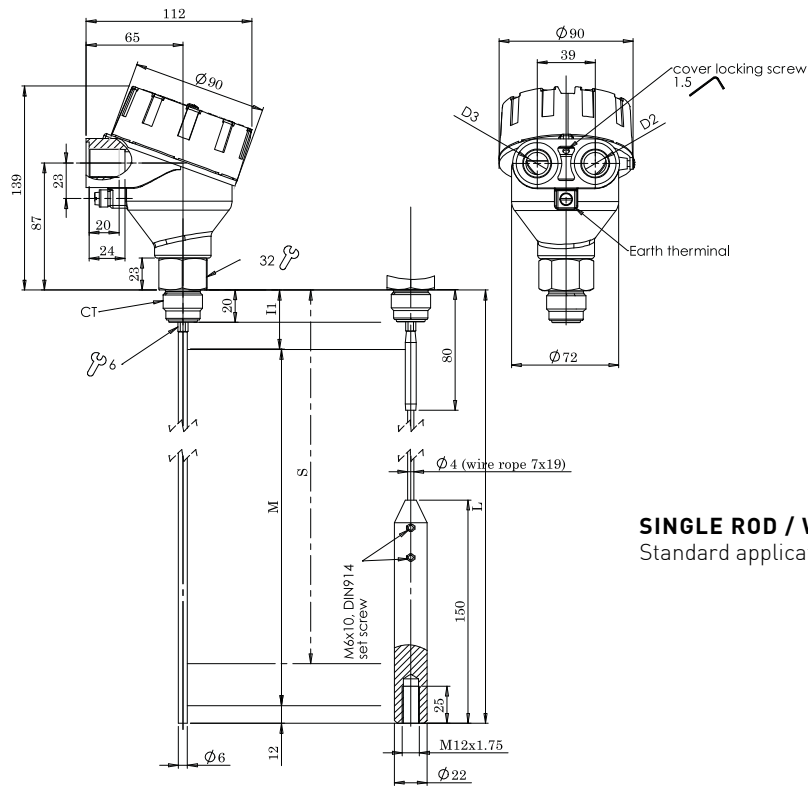

SINGLE ROD / WIRE ROPE PROBE
Standard application temperature

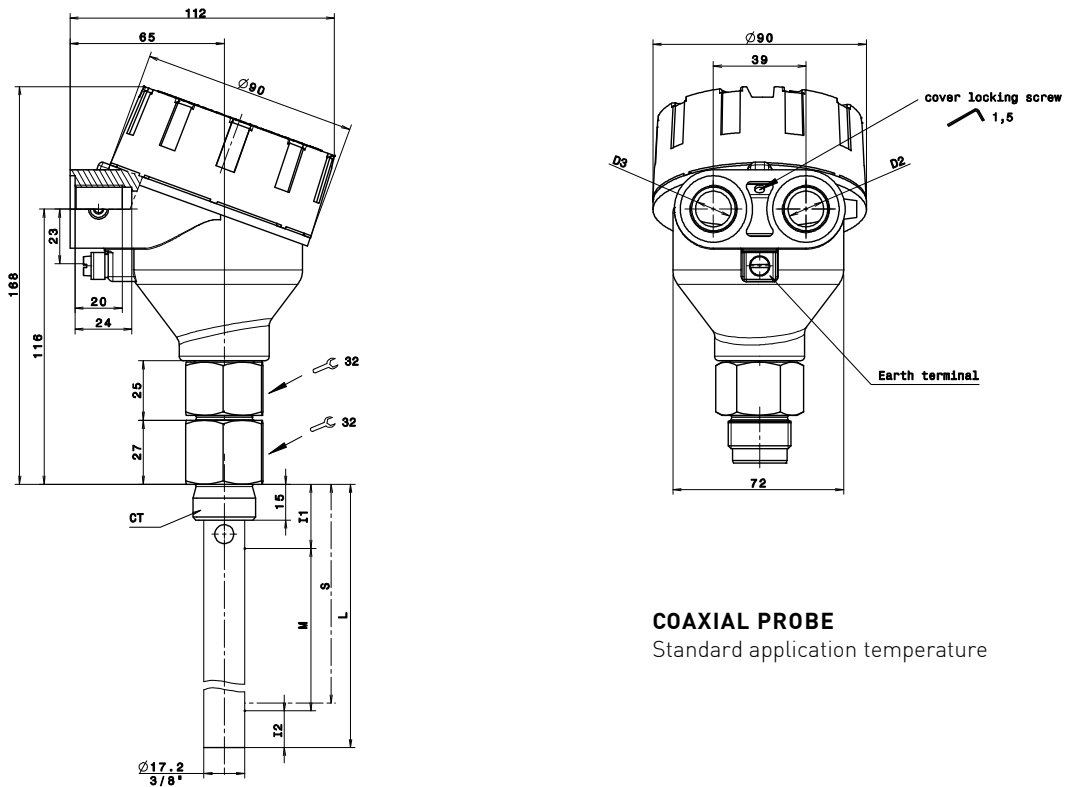

COAXIAL PROBE
Standard application temperature

DIMENSIONS IN MM

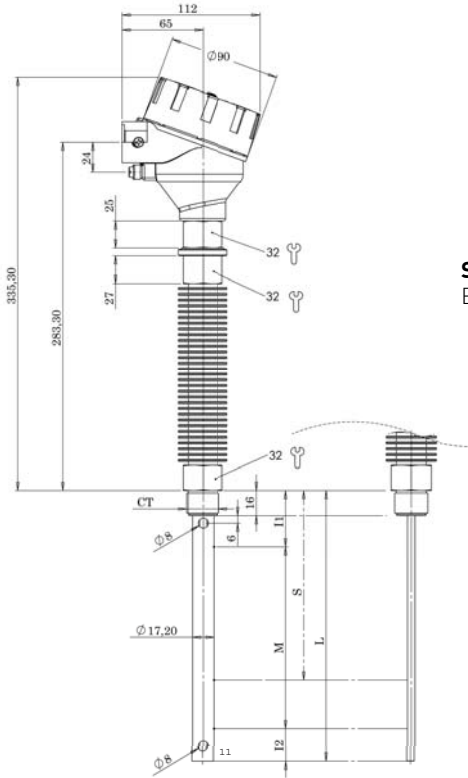

SINGLE ROD / COAXIAL PROBE
Extended application temperature

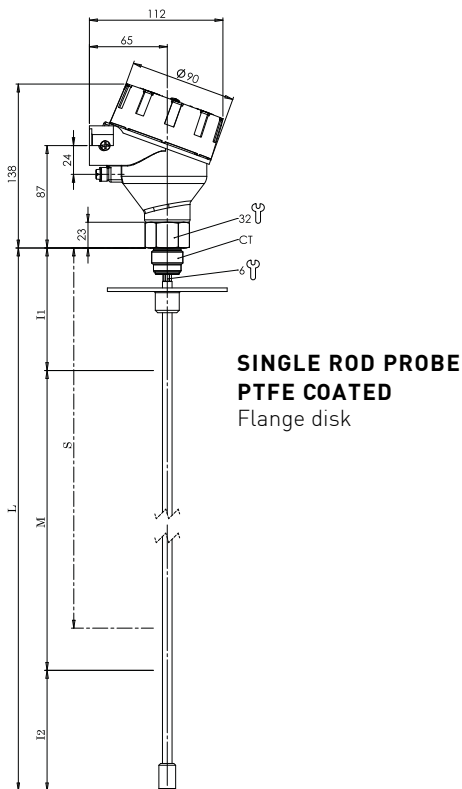

**SINGLE ROD PROBE
PTFE COATED**
Flange disk

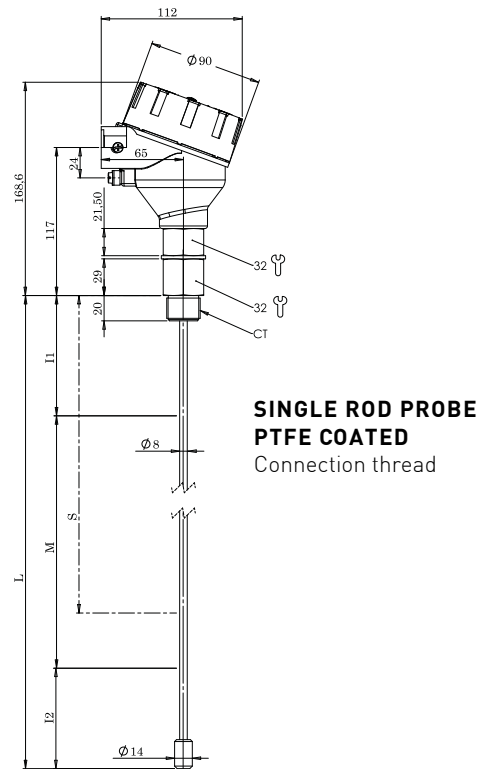

**SINGLE ROD PROBE
PTFE COATED**
Connection thread

