

SPECIAL FEATURES

- EXTERNAL ZERO ADJUSTMENT (OPTIONAL)
- STAINLESS STEEL CASE & MEASURING SYSTEM
- SOCKET DIRECTLY WELDED TO CASE
- DRY AND LIQUID FILLED VERSION
- STANDARD FOLLOWED EN 837-1 (FOR NS 100, 150 & 250 mm).
- CE MARKING (AS PER PED 97/23/EC) (FOR NS 100 mm & 150 mm)

APPLICATIONS

FOOD & BEVERAGE, PHARMACEUTICAL, CRYOGENICS, CHEMICAL & PETROCHEMICAL INDUSTRIES, CONVENTIONAL & NUCLEAR POWER PLANTS, PUMPS, HYDRO-CLEANING MACHINES, PRESSES, ENGINE COMPRESSORS, TURBINES, DIESEL ENGINES & REFRIGERATING PLANTS. SUITABLE FOR CORROSIVE ENVIRONMENTS & GASEOUS OR LIQUID MEDIA THAT WILL NOT OBSTRUCT THE PRESSURE SYSTEM.



SPECIFICATIONS

STANDARD VERSION : 100 mm, 125 mm, 150 mm, 200 mm & 250 mm

Accuracy	: ±1.0% of F.S.
Ambient temperature	: - 25°C to + 65°C
Process temperature	: Max 300°C
Operating Pressure Range	: 75% of Scale Value
Over pressure limit	: ≤ 100 bar : 125% of Max. Scale Value
	: > 100 to ≤ 600 bar : 115% of Max. Scale Value
	: > 600 to ≤ 1600 bar : 110% of Max. Scale Value

Case & Bezel	: AISI 304 SS (Bayonet Type)
Bourdon	: AISI 316L SS
Socket	: AISI 316L SS (Directly Welded to Case)
Movement	: AISI 304 SS
Joints	: Tig Argon Arc Welding

Protection	: IP 65
Dial	: Aluminium, black graduation on white background
Pointer	: Aluminium, black coloured Micrometer zero adjustable
Window	: Sheet Glass
Blow off Disc	: Neoprene
Gasket & Filling Plug	: Neoprene

DRY BUT FILLABLE VERSION (OPTION FG)

Fillable Dampening Liquid	: Glycerine 99.7% (Option - FG)
Ambient Temperature	: Maximum 65°C
Process Temperature	: Maximum 65°C
Window	: Plexi Glass
Other Features	: Refer Specification of Standard Version

GLYCERINE FILLED VERSION (OPTION PY)

Accuracy	: ±1.0% of F.S.
Ambient Temperature	: Maximum 65°C
Process Temperature	: Maximum 65°C
Window	: Plexi Glass
Dampening Liquids	: Glycerine 99.7% (others available as option)
Other Features	: Refer Specification of Standard Version

Temperature effect:

The variation of indication caused by effects of temperature is to be calculated by below formula; which is to be added in the specified accuracy while measurement :- Formula : $\pm 0.04 \times (t_2 - t_1) \%$ of F. S. where t_1 = reference temperature (+20°C) and t_2 = ambient temperature in °C.

DIMENSIONS - STANDARD VERSION

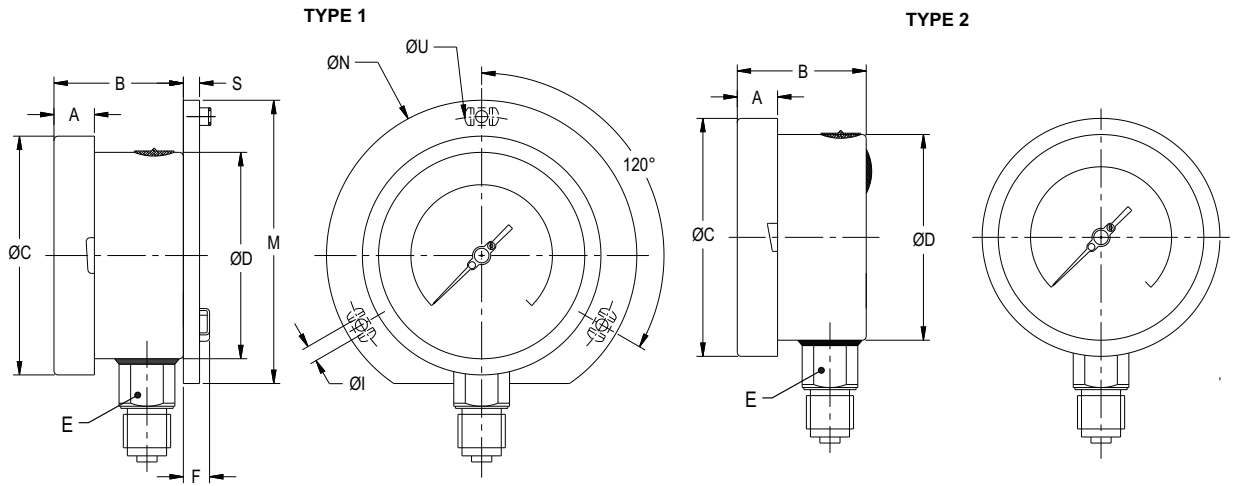

NS	A	B	ØC	ØD	E	M	S	F	ØI	ØN	ØU	Weight in gram (With Box)	Weight in gram (With Glycerin & Box)
100	12.5	45	111	100	22	128	6	14.5	6	134	118	720.0	1025.0
125	15	46	129	119	22	-	4	14.5	6	150	137	845.0	1165.0
150	15	46.5	161	149	22	174.5	6	14.5	6	186	168	1160.0	1895.0
200	18	49	216.5	201.5	22	-	1.5	14.5	7	245	230	2020.0	2780.0
250	18	52	263	250	22	286.5	1.5	14.5	7	290	276	2400.0	3220.0

NS	A	B	ØC	ØD	E	Weight in gram (With Box)	Weight in gram (With Glycerin & Box)
100	12.5	47	111	100	22	640.0	935.0
125	15	48	129	119	22	750.0	1070.0
150	15	49	161	149	22	1020.0	1755.0
200	18	49	210.5	201.5	22	1720.0	2480.0
250	18	52	263	250	22	2000.0	2820.0

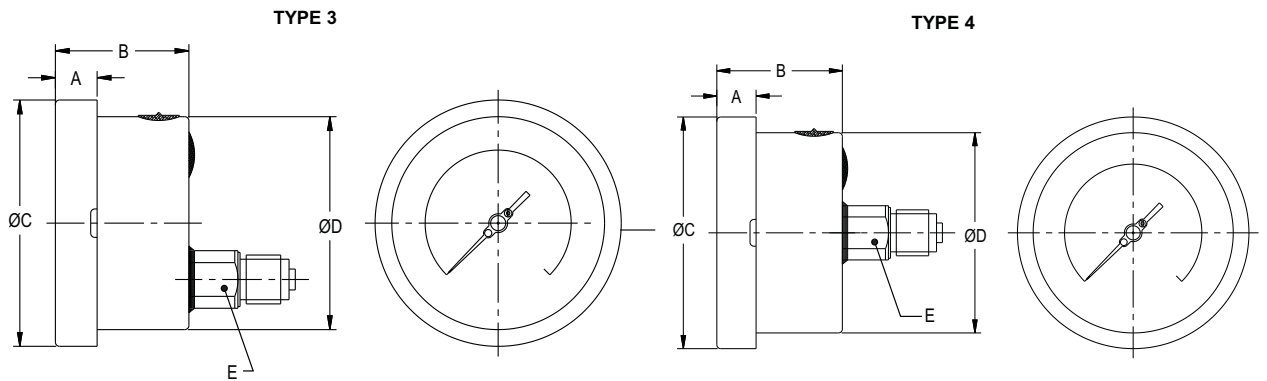

NS	A	B	ØC	ØD	E	Weight in gram (With Box)	Weight in gram (With Glycerin & Box)
100	12.5	47	111	100	22	640.0	935.0
125	15	48	129	119	22	750.0	1070.0
150	15	49	161	149	22	1000.0	1735.0
200	18	49	216.5	201.5	22	1500.0	2260.0
250	18	52	263	250	22	1800.0	2620.0

NS	A	B	ØC	ØD	E	Weight in gram (With Box)	Weight in gram (With Glycerin & Box)
100	12.5	47	111	100	22	640.0	935.0

TYPE 5

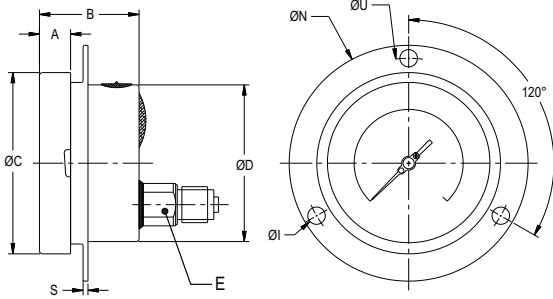

TYPE 11

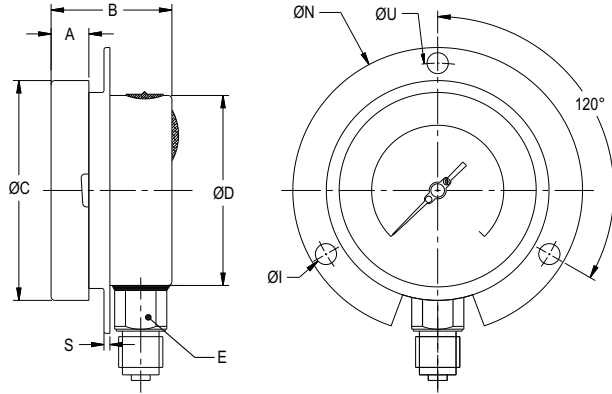

NS	A	B	ØC	ØD	E	S	ØI	ØN	ØU	Weight in gram (With Box)	Weight in gram (With Glycerin & Box)
100	12.5	47	111	100	22	1	6	134	118	695.0	990.0
125	15	48	129	119	22	4	6	150	137	850.0	1170.0
150	15	49	161	149	22	5	6	186	168	1100.0	1835.0
200	18	49	216.5	201.5	22	1.5	7	245	230	2000.0	2760.0
250	18	52	263	250	22	1.5	7	290	276	2250.0	3070.0

NS	A	B	ØC	ØD	E	S	ØI	ØN	ØU	Weight in gram (With Box)	Weight in gram (With Glycerin & Box)
100	12.5	47	111	100	22	1	6	134	118	730.0	1025.0
125	15	48	129	119	22	4	6	150	137	815.0	1135.0
150	15	49	161	149	22	5	6	186	168	1100.0	1835.0

TYPE 9

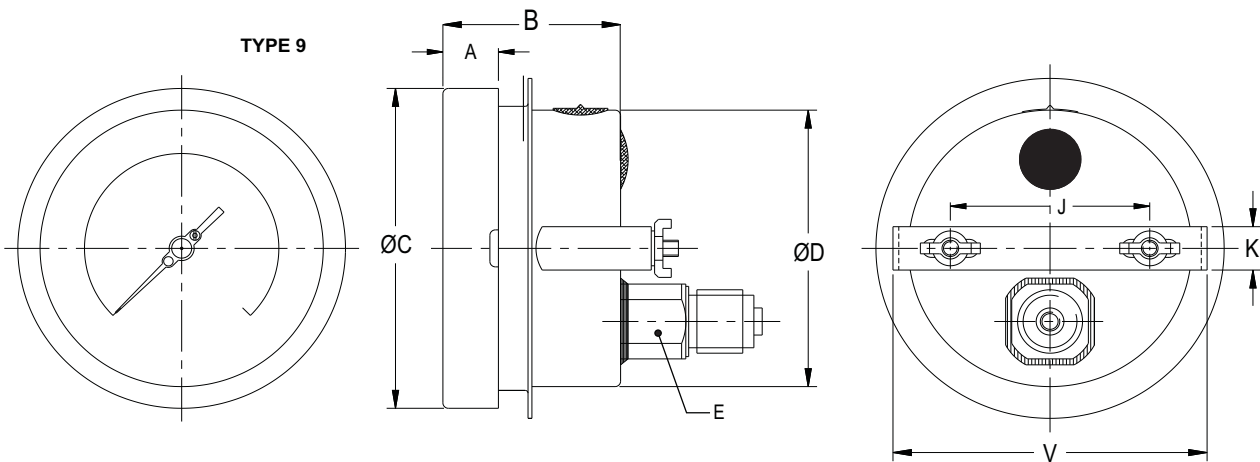

NS	A	B	ØC	ØD	E	J	K	V	Weight in gram (With Box)	Weight in gram (With Glycerin & Box)
100	12.5	47	111	100	22	72	16	108	740.0	1035.0
125	15	48	129	119	22	75	16	125	890.0	1210.0
150	15	49	161	149	22	106.5	16	166	1100.0	1835.0
200	18	49	210.5	201.5	22	165	16	208	1920.0	2680.0
250	18	52	263	250	22	180	30	270	2300.0	3120.0

Notes : • Drawings are not to scale. • All Dimensions are in mm . • NS = Nominal Seize

• Weights mentioned are approximate and for standard product. Weight can be different after selection of options.

We Sense • We Measure • We Control



RANGE TABLE

Note : Waaree offers National / International Scales like kPa, MPa, bar, psi, kg/cm² & Dual Scale like kPa with psi, kPa with bar, bar with psi or Equivalent scales as per the requirement can be provided on request. Following are the example tables for kg/cm² & psi scales

PRESSURE

SINGLE SCALE (kg/cm ² or bar)				
0/0.6	0/4	0/25	0/160	0/1000
0/1	0/6	0/40	0/250	0/1600
0/1.6	0/10	0/60	0/400	0/2100
0/2.5	0/16	0/100	0/600	

DUAL SCALE (psi with kg/cm ²)					
psi	kg/cm ²	psi	kg/cm ²	psi	kg/cm ²
0/15	0/1	0/400	0/28	0/4000	0/280
0/30	0/2	0/500	0/35	0/5000	0/350
0/60	0/4	0/600	0/40	0/6000	0/420
0/100	0/7	0/1000	0/70	0/10000	0/700
0/150	0/10	0/1500	0/100	0/15000	0/1000
0/220	0/16	0/2200	0/160	0/22000	0/1600
0/300	0/20	0/3000	0/200	0/30000	0/2000

VACUUM & COMPOUND

DUAL SCALE (inHg with psi & mmHg with kg/cm ²)					
inHg with psi	mmHg with kg/cm ²	inHg with psi	mmHg with kg/cm ²	inHg with psi	mmHg with kg/cm ²
- 30/0	- 760/0	- 30/60	- 760/4	- 30/200	- 760/14
- 30/15	- 760/1	- 30/100	- 760/7	- 30/300	- 760/21
- 30/30	- 760/2	- 30/150	- 760/10	- 30/350	- 760/25

SINGLE SCALE (kg/cm ²)			
- 1/0	- 1/1.5	- 1/5	- 1/15
- 1/0.6	- 1/3	- 1/9	- 1/24

RECEIVER

LINEAR SCALE (0 - 100% Internal Scale) External Scale 0.2 - 1 kg/cm ² or 3 - 15 psi (0-100% linear scale)	SQUARE ROOT SCALE (0 - 10 Sq - Root Internal Scale) External Scale 0.2 - 1 kg/cm ² or 3 - 15 psi (0.2 - 1 kg/cm ²)
--	---

FREON (WITH TEMPERATURE SCALE)

AMMONIA (WITH TEMPERATURE SCALE)

Note : For temperature scales, please provide refrigerant name.

RANGE (psi)				
-30 inHg - 150	0-300		-1 to 12.5	-30 inHg - 150
-30 inHg - 300	0-500		-1 to 16	-30 inHg - 300
			-1 to 25	0 - 300

ACCESSORIES (Refer Datasheet for complete specifications)

EB COOLING TOWER	ED OVER LOAD PROTECTOR (GAUGE SAVER)**	EG SNUBBER
EC GAUGE COCK	* NEEDLE VALVE	EH SIPHON

* Refer catalogue for Valves & Manifolds.

** For Pressure Ranges.

We Sense • We Measure • We Control



Example

HOW TO ORDER

BASIC MODEL

CODE

NOMINAL SIZE	F	G	H	I	J
	100 mm	125 mm	150 mm	200 mm	250 mm

TYPE OF MOUNTING

- 1 WALL / SURFACE / PROJECTION MOUNTING WITH BOTTOM ENTRY
- 2 DIRECT BOTTOM ENTRY
- 3 DIRECT LOWER BACK ENTRY
- 4 DIRECT CENTER BACK ENTRY (FOR NS 100 mm ONLY)
- 5 LOWER BACK ENTRY WITH FRONT FLANGE
- 6 2" PIPE / YOKE MOUNTING WITH BOTTOM ENTRY*
- 9 LOWER BACK ENTRY WITH MOUNTING BRACKET
- 11 BOTTOM ENTRY WITH FRONT FLANGE (FOR NS 100 mm, 125 mm & 150 mm)

* MOC OF BRACKET AND 'U' CLAMP WILL BE STEEL (PAINTED). ASK FACTORY FOR DRAWINGS, IF REQUIRED.

GAUGE CONNECTION

	F	G	H	I	J
2BM 1/4" BSP(M)	✓	✓	✓	X	X
2NM 1/4" NPT(M)	✓	✓	✓	X	X
2TM 1/4" BSPT(M)	✓	✓	✓	X	X
3BM 3/8" BSP(M)	✓*	✓	✓	✓	✓
3TM 3/8" BSPT(M)	✓	✓	✓	✓	✓
4BM 1/2" BSP(M) STANDARD	✓	✓	✓	✓	✓
4NM 1/2" NPT(M) STANDARD	✓	✓	✓	✓	✓
4TM 1/2" BSPT(M)	✓	✓	✓	✓	✓
4MM M 20x 1.5(M)	✓	✓	✓	✓	✓

* Standard for NS 100 mm.

Note : Connections like Metric/ PT/ PF/ Flaired/ UNF/ G/ R etc. can be provided on request.

RANGE

REFER RANGE TABLE

OPTIONAL EXTRAS

OA ACCURACY ± 0.5% OF F.S (FOR DRY VERSION)	SX SS TAG PLATE
TI MONEL BOURDON & SOCKET (MONEL VERSION)**	SW DIAL TAG MARKING
FL INTEGRAL DAMPENING SCREW (MONEL)**	TB HELIUM LEAK TEST
FS FILLABLE LIQUID SILICON OIL*	TF CONFORMITY AS PER NACE MR 0175
FG FILLABLE LIQUID GLYCERINE	PW FIVE POINT CALIBRATION CERTIFICATE
PZ DAMPENING LIQUID MINERAL LIQUID FILLED	PU CALIBRATION CERTIFICATE TRACEABLE TO NATIONAL/INTERNATIONAL STANDARDS
PX DAMPENING LIQUID FLOUROLUBE FILLED	SG OXYGEN SERVICE (FOR DRY VERSION)
PY DAMPENING LIQUID GLYCERINE FILLED	RH CUSTOM DESIGNED DIAL
QA DAMPENING LIQUID SILICON OIL FILLED*	QB INTEGRAL DAMPENING SCREW (AISI 316 SS)
RR ENCLOSURE PROTECTION IP 66	SA INTERNAL OVERPRESSURE STOP
RE ENCLOSURE PROTECTION IP 67	SB INTERNAL VACUUM STOP
RW PLEXI GLASS	ZB RECEIVER RANGE
RX SHATTERPROOF/SAFETY GLASS	ZC FREON RANGE (WITH TEMPERATURE SCALE)
RZ TOUGHENED GLASS	ZD AMMONIA RANGE (WITH TEMPERATURE SCALE)
SF MOVEMENT WITH DAMPENING JELLY	PS AISI 316 SS CASE & BEZELS
SI KNIFE EDGE POINTER	SD AISI 316 SS MOVEMENT
SJ MAXIMUM READING POINTER WITH PLEXI GLASS (EXCEPT OPTION OA & ONLY FOR DRY VERSION)S	CK EPOXY PAINTED CASE & BEZEL
CE CE MARKING (AS PER PED 97/23/EC)SS	ZM ELECTRO POLISHED CASE & BEZEL
GH MATERIAL TEST CERTIFICATES***	SQ CASE WITH ROLLING TYPE BEZEL (FOR NS 100 mm)
KA ON - OFF TYPE VENT PLUG	ZL OVER RANGE PROTECTION 150% OF F. S.
PV IBR APPROVAL#	JU 2" PIPE/YOKE MOUNTING BRACKET & 'U' CLAMP (AISI 304 SS)
RG ANTI PARALLAX MIRROR BAND DIAL##	FN 2" PIPE/YOKE MOUNTING BRACKET & 'U' CLAMP (AISI 316 SS)
EZ EXTERNAL ZERO ADJUSTMENT (EXCEPT MOUNTING TYPE 5 & 11)	GO SHORT OVERPRESSURE

* Gasket & Filling plug of NBR. Refer Price List for Viton.

**INTEGRAL DAMPENING SCREW WILL BE IN MONEL IF ORDERED. REFER OPTION FL.

*** MATERIAL TEST CERTIFICATES WILL BE PROVIDED FOR WETTED PARTS ONLY WITH CHEMICAL COMPOSITION TESTING. FOR OTHERS, PLEASE CONSULT FACTORY.

FOR NS 150 mm & ABOVE. SCALE SHALL BE MARKED IN kg/cm² ONLY. CONSULT FACTORY FOR MORE DETAILS.

FOR NS 150 mm & ABOVE. ● FOR NS 100 mm to 150 mm. ●● FOR NS 100 mm & 150 mm.

Ordering Example: AL - X - X OR XX - XXX - 0/10 kg/cm² - XX

FOR OTHER OPTIONAL ITEMS, PLEASE CONTACT FACTORY FOR DELIVERY AND MINIMUM QUANTITY OF ORDER.

Note : Specifications and dimensions given in this product catalogue represents the state of engineering at the time of printing.

Modifications may take place and materials specified may be replaced by others without prior notice.

We Sense • We Measure • We Control

