

Level switches (two-term level controllers)

ERH-xx-04,-06,-07,-16,-16.1

Description

The limit level signalling or two-term liquid level control in the open or closed pressure tanks. The basic versions, ERH-xx-16 and ERH-xx-16.1 are also produced in explosion-proof atmosphere, corresponding to the class II 1/2G c Ex de IIB T4 Ga/Gb. The level switches can operate in neutral liquids, or aggressive ones not acting on 316/316L stainless steel in marine conditions, while thanks to variety of versions and additional accessories it is possible to adapt the device to specific conditions of the concrete application.



Approvals and certificates

Type	Description	Ingress Protection	ATEX	DNV-GL	LR	BV	PRS	PZH
ERH-xx-04	Standard version	IP66						●
ERH-xx-06	Marine version	IP66		●	●	●	●	●
ERH-xx-07	Marine version for operation at full submersion	IP68		●	●	●	●	
ERH-xx-16	Marine version for operation in explosion risk zones	IP66	●	●	●	●	●	
ERH-xx-16.1	Marine version for operation in explosion risk zones at full submersion	IP68	●	●	●	●	●	

Types of the level switches

Type	Description	Visual principal drawing – kinds of versions
ERH-01-	Version with steady hysteresis of switching (10mm, 20mm or 30mm)	
ERH-02-	Version with steady hysteresis of switching (10mm, 20mm or 30mm) and protection of float stem against contamination	
ERH-03-	Version with adjusted hysteresis of switching (50...250mm or 100...400mm)	
ERH-04-	Version with adjusted hysteresis of switching (32...1350mm) mounting only from the top	

Dimensions

ERH-01-

Type	H [mm]	L [mm]	Hysteresis [mm]
ERH-01-04-1	120	190	10
ERH-01-06-1			
ERH-01-07-1			
ERH-01-16-1	140	230	10
ERH-01-16.1-1			
ERH-01-04-2	140	230	20
ERH-01-06-2			
ERH-01-07-2			
ERH-01-16-2	180	305	20
ERH-01-16.1-2			
ERH-01-04-3	150	255	30
ERH-01-06-3			
ERH-01-07-3			
ERH-01-16-3	240	405	30
ERH-01-16.1-3			

Controller with broken arm

single L-type (dimensions A and B)
double Z-type (dimensions A, B and C)

$A+B=\max.1000\text{mm}$ and $A/B\leq 4$

Options available for the
ERH-01- and ERH-02- versions.

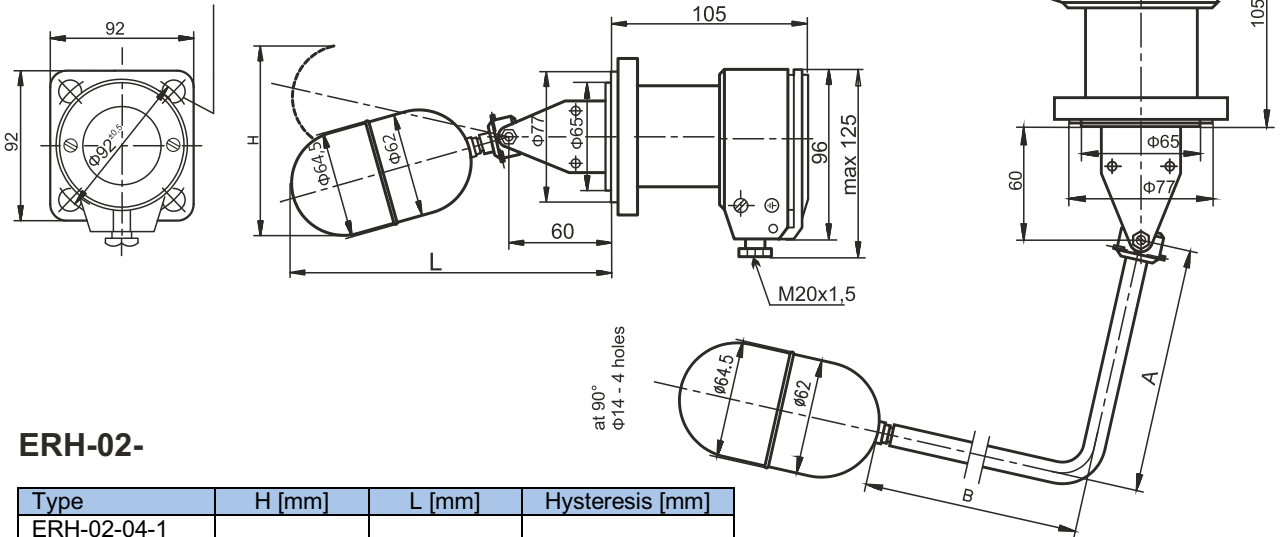

ERH-02-

Type	H [mm]	L [mm]	Hysteresis [mm]
ERH-02-04-1	120	190	10
ERH-02-06-1			
ERH-02-07-1			
ERH-02-16-1	140	230	10
ERH-02-16.1-1			
ERH-02-04-2	140	230	20
ERH-02-06-2			
ERH-02-07-2			
ERH-02-16-2	180	305	20
ERH-02-16.1-2			
ERH-02-04-3	150	255	30
ERH-02-06-3			
ERH-02-07-3			
ERH-02-16-3	240	405	30
ERH-02-16.1-3			

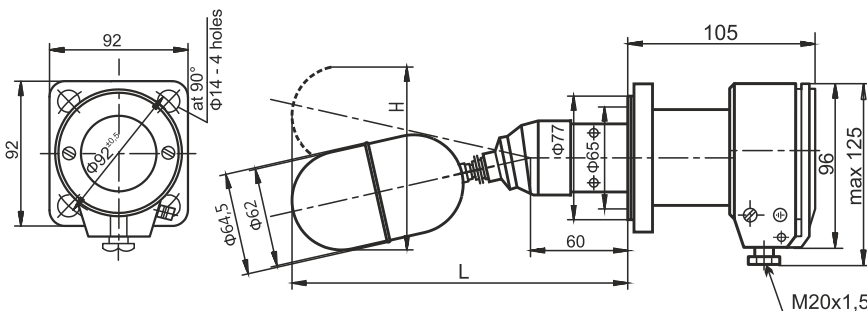
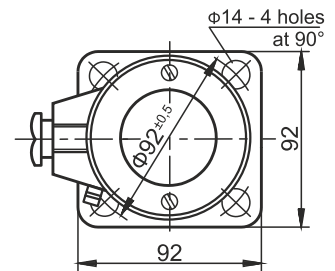

ERH-03-

Type	H [mm]	L [mm]	Hysteresis [mm]
ERH-03-04-1 ERH-03-06-1 ERH-03-07-1	680	510	100...400
ERH-03-16 ERH-03-16.1	680	510	50...400
ERH-03-04-2 ERH-03-06-2 ERH-03-07-2	450	380	50...250

Float in standard version:

- ER2- 101 for ERH-01(02)-04-1
ERH-01(02)-06-1
ERH-01(02)-07-1
- ER2-1024 for other types of ERH

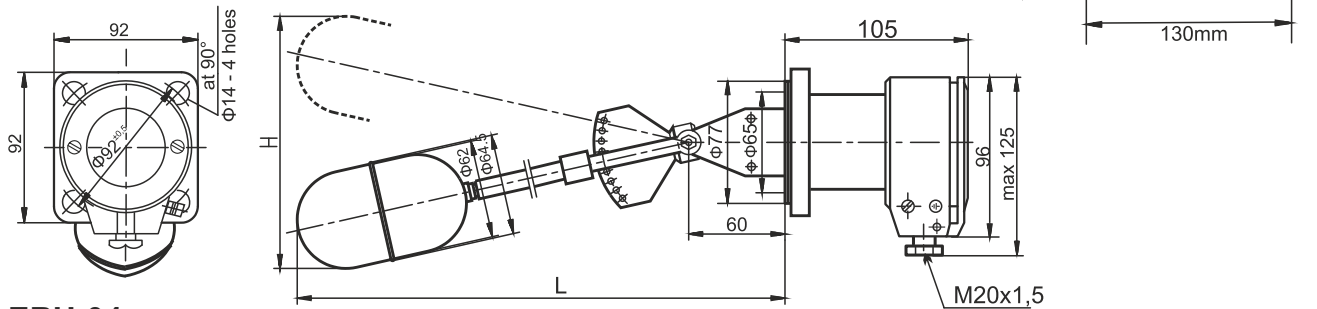

ERH-04-

Float in optional version:

- ER2-1661-1 for ERH-01(02)-04-1
ERH-01(02)-06-1
ERH-01(02)-07-1
- ER2-1661-2 for other types of ERH

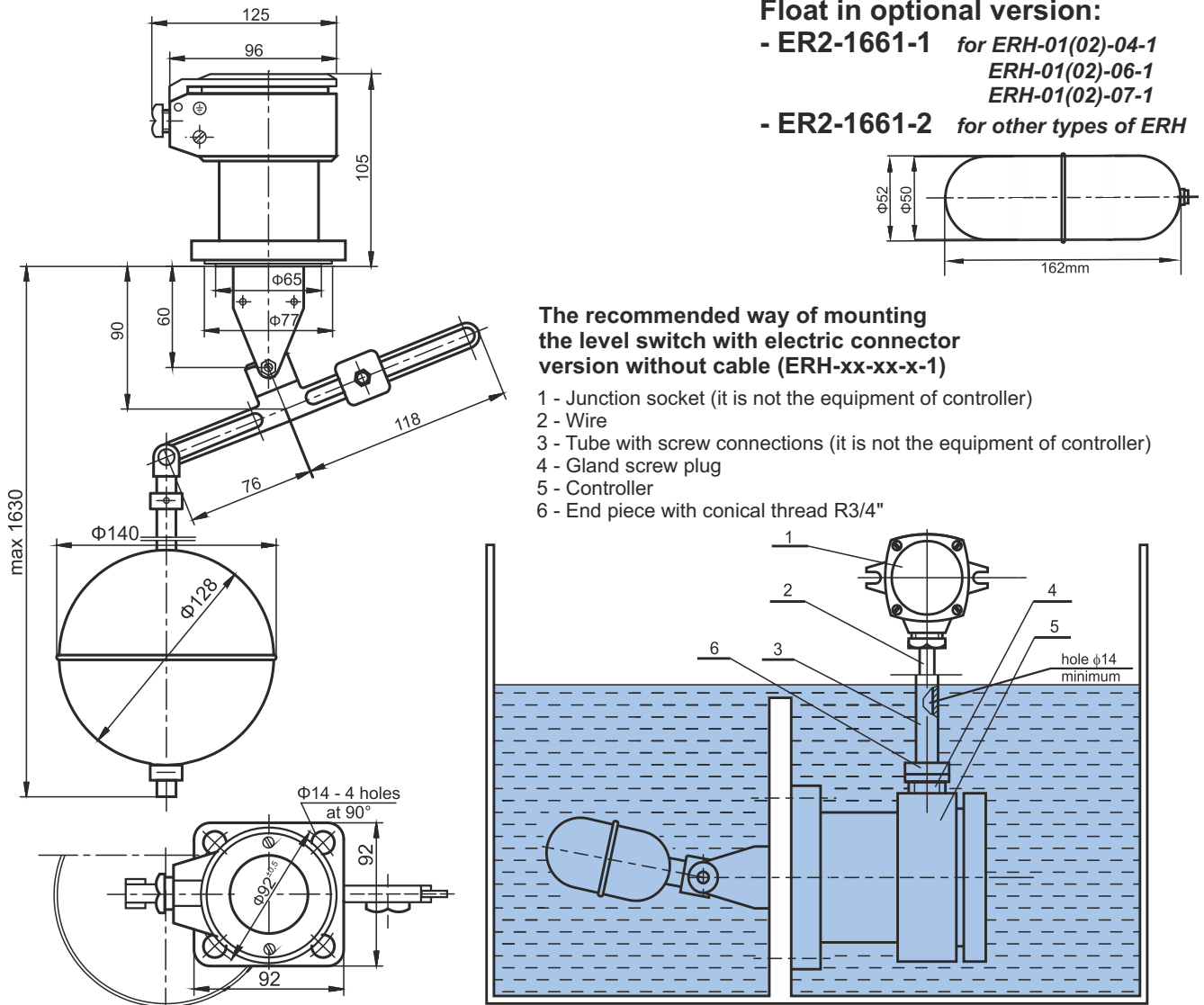

The recommended way of mounting the level switch with electric connector version without cable (ERH-xx-xx-x-1)

- 1 - Junction socket (it is not the equipment of controller)
- 2 - Wire
- 3 - Tube with screw connections (it is not the equipment of controller)
- 4 - Gland screw plug
- 5 - Controller
- 6 - End piece with conical thread R3/4"

- 1 Float level switch in standard version with steady hysteresis of switching 10, 20 or 30mm
- 2 Float level switch mounted from the top with hysteresis of switching in the scope of 32...1350mm (2000mm in option)
- 3 Float level switch with Z-type arm, making possible the shift of switching point in relation to the already existing place of mounting
- 4 Magnetic level switch mounted from the top with 1, 2 or 3 switching points
- 5 Float level switch in standard version with testing device (screwed or welded)
- 6 Float level switch with possibility of switching hysteresis setting in the scope of 50...250mm or 100...400mm

- 7 Float level switch designed for operation at full submersion
- 8 Magnetic level switch in mini version for places of limited space
- 9 Float level switch with L-type arm, making possible the mounting from the top and applying at places of limited space instead of level switch 2; in version ERH-xx-16.1 with IP68 protection degree signalling of the media in 0 zone is possible, while the immersed device casing must be installed out of 0 zone
- 10 Float level switch with float arm casing protecting against contaminations

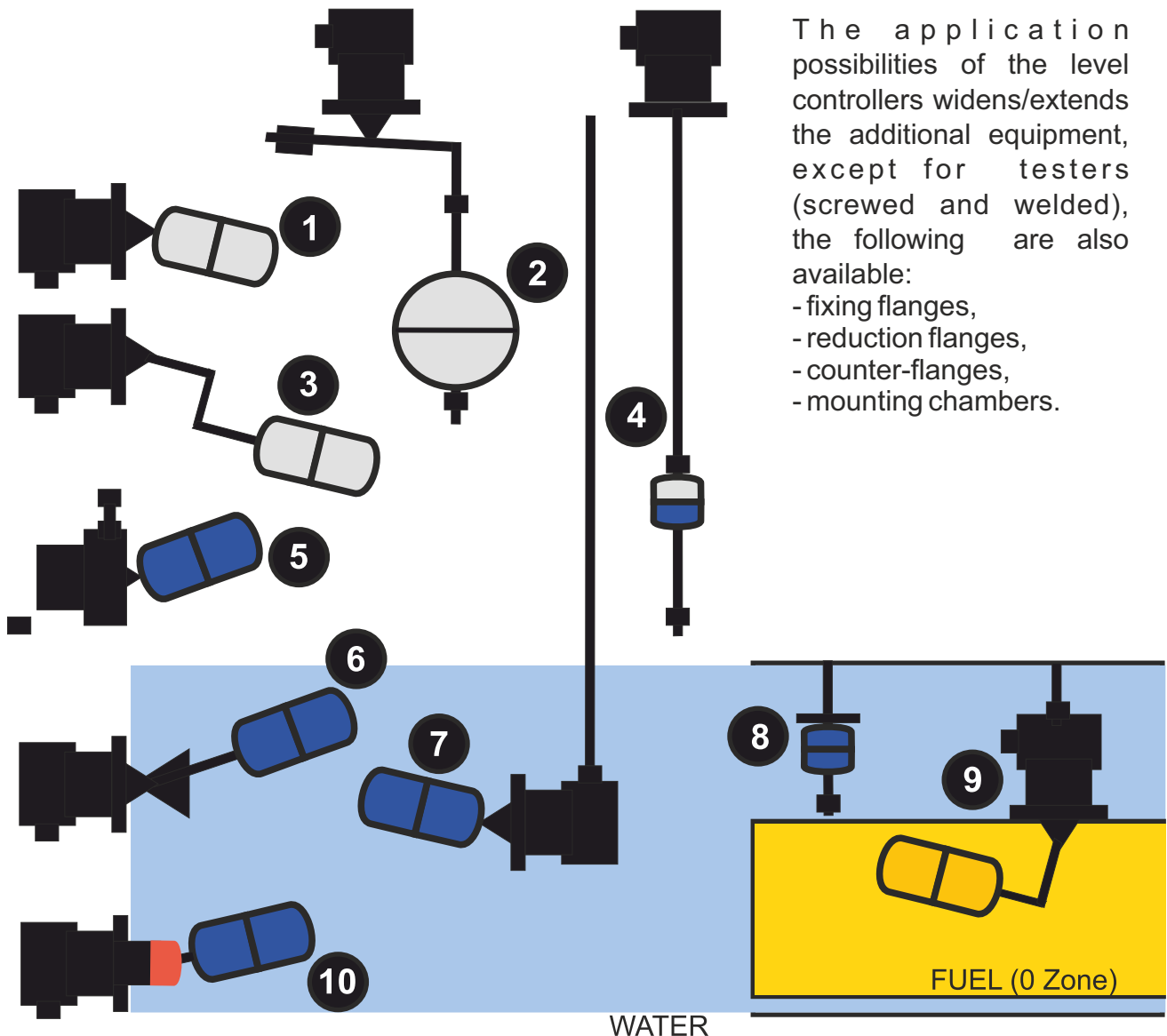

Ordering

ERH-xx-04 *standard version with IP66*

ERH-xx-06 *marine version with IP66*

ERH-01-04	Two-term level controller	
ERH-02-04	Two-term level controller (with float arm protection against contaminations)	
ERH-01-06	Two-term level controller - marine version	
ERH-02-06	Two-term level controller (with float arm protection against contaminations) - marine version	
	-1	Hysteresis of switching 10mm
	-2	Hysteresis of switching 20mm
	-3	Hysteresis of switching 30mm
	-4-0	Broken arm of float A=125mm B=125mm
	-4-1	Broken arm of float A=185mm B=80mm
	-4-2	Broken arm of float A=250mm B=125mm
	-4-3	Broken arm of float A=140mm B=120mm
	-4-4	Broken arm of float A=100mm B=120mm
	-4-5	Broken arm of float A=120mm B=80mm
	-4-6	Broken arm of float A=150mm B=80mm
	-4-x	Broken arm of float, acc. to the client's request *
	-k	Acidproof version

* the broken arm L-type one must meet the condition of $A+B=\max. 1000\text{mm}$ and $A/B=\max. 4$; the broken arm Z-type

ERH-03-04	Two-term level controller	
ERH-03-06	Two-term level controller - marine version	
	-1	Adjustable hysteresis of switching in the scope of 100...400mm
	-2	Adjustable hysteresis of switching in the scope of 50...250mm
	-k	Acidproof version

ERH-04-04	Two-term level controller	
ERH-04-04	Two-term level controller - marine version	
	-k	Acidproof version

Example of the controller denotation

The two-term level controller with steady hysteresis of switching 10mm **ERH-01-04-1**

Ordering

ERH-xx-07 marine version for operation at full submersion with IP68

ERH-01-07	Two-term level controller	
ERH-02-07	Two-term level controller (with float arm protection against contaminations)	
	-1	Hysteresis of switching 10mm
	-2	Hysteresis of switching 20mm
	-3	Hysteresis of switching 30mm
	-4-0	Broken arm of float A=125mm B=125mm
	-4-1	Broken arm of float A=185mm B=80mm
	-4-2	Broken arm of float A=250mm B=125mm
	-4-3	Broken arm of float A=140mm B=120mm
	-4-4	Broken arm of float A=100mm B=120mm
	-4-5	Broken arm of float A=120mm B=80mm
	-4-6	Broken arm of float A=150mm B=80mm
	-4-x	Broken arm of float, acc. to the client's request *
	-1	Without cable
	-2	With cable of 3m length **
	-k	Acidproof version

* the broken arm L-type one must meet the condition of $A+B=\max. 1000\text{mm}$ and $A/B=\max. 4$; the broken arm Z-type

** other cable lengths

ERH-03-07	Two-term level controller	
	-1	Adjustable hysteresis of switching in the scope of 100...400mm
	-2	Adjustable hysteresis of switching in the scope of 50...250mm
	-1	Without cable
	-2	With cable of 3m length **
	-k	Acidproof version

** other cable lengths upon the order

ERH-04-07	Two-term level controller	
	-1	Without cable
	-2	With cable of 3m length **
	-k	Acidproof version

** other cable lengths upon the order

Example of the controller denotation

The two-term level controller fully acidproof with float arm protection against contaminations with steady hysteresis of switching 30mm with cable of 15m length **ERH-02-07-3-2-k with 15m cable**

Ordering

ERH-xx-16 marine version in explosion risk zones with IP66

ERH-xx-16.1 marine version for operation at full submersion
and in explosion risk zones with IP68

ERH-01-16	Two-term level controller - IP66	
ERH-02-16	Two-term level controller (with float arm protection against contaminations) - IP66	
ERH-01-16.1	Two-term level controller - IP68	
ERH-02-16.1	Two-term level controller (with float arm protection against contaminations) - IP68	
	-1	Hysteresis of switching 10mm
	-2	Hysteresis of switching 20mm
	-3	Hysteresis of switching 30mm
	-4-0	Broken arm of float A=125mm B=125mm
	-4-1	Broken arm of float A=185mm B=80mm
	-4-2	Broken arm of float A=250mm B=125mm
	-4-3	Broken arm of float A=140mm B=120mm
	-4-4	Broken arm of float A=100mm B=120mm
	-4-5	Broken arm of float A=120mm B=80mm
	-4-6	Broken arm of float A=150mm B=80mm
	-4-x	Broken arm of float, acc. to the client's request *

* the broken arm L-type one must meet the condition of $A+B=\max. 1000\text{mm}$ and $A/B=\max. 4$; the broken arm Z-type on request

ERH-03-16	Two-term level controller - IP66 (adjustable hysteresis 50...400mm)
ERH-03-16.1	Two-term level controller - IP68 (adjustable hysteresis 50...400mm)

ERH-04-16	Two-term level controller - IP66 (adjustable hysteresis 50...400mm)
ERH-04-16.1	Two-term level controller - IP68 (adjustable hysteresis 50...400mm)

Example of the controller denotation

The two-term level controller with adjustable hysteresis of switching 50...400mm **ERH-03-16**

Testing devices (screwed or welded)

Description

The testing devices (testers) are designed for mechanical checking of the controller operation correctness, without necessity of dismounting of the device from the tank.

The testers can cooperate with the level switches in version ERH-01- or ERH-03-.



Tester for separable mounting (screwed) type ER3-1560

Material	St3S steel	(ER3-1560-1)
	316L stainless steel	(ER3-1560-2)
Weight	1,5 kg	

Example of the controller mounting with the tester ER3-1560

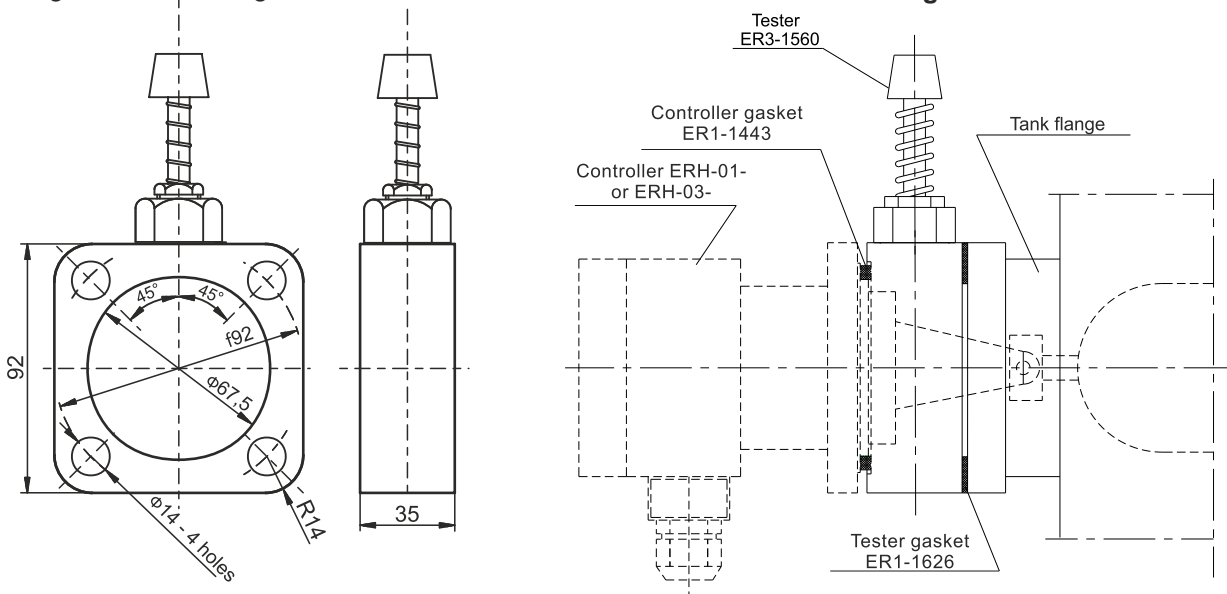

Tester for steady mounting (welded) type ER3-1495

Material	St3S steel
Weight	1,5 kg

Example of the controller mounting with the tester ER3-1495

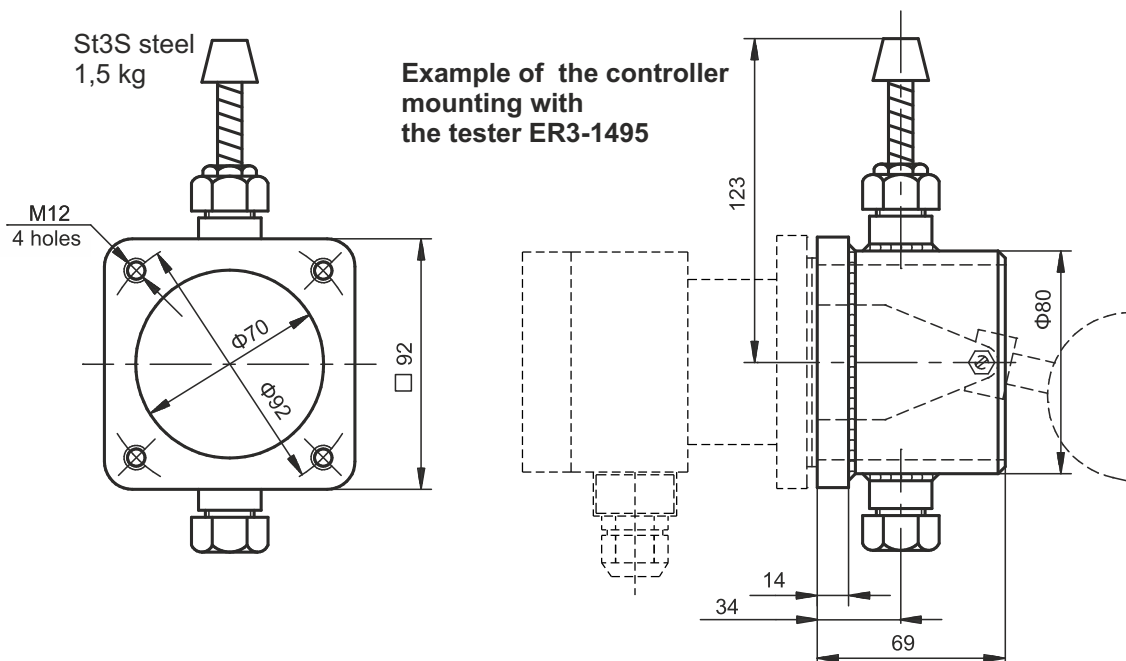

Fixing and reduction flanges

Description

The fixing flanges or reduction flanges are used in cases when the tank counter-flange has the connection dimensions different from the standard flange of controller 92x92mm. The fixing flanges can be used for all the versions of two-term controllers.

Application of the reduction flanges is limited by their width which influences the float operation range.

Example of the controller mounting with the flange ER2-1587

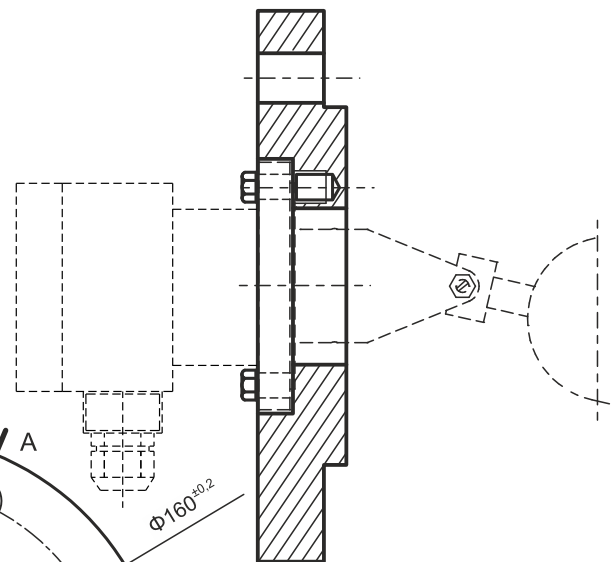

Fixing flange DN80 type ER2-1587

Material 316L stainless steel

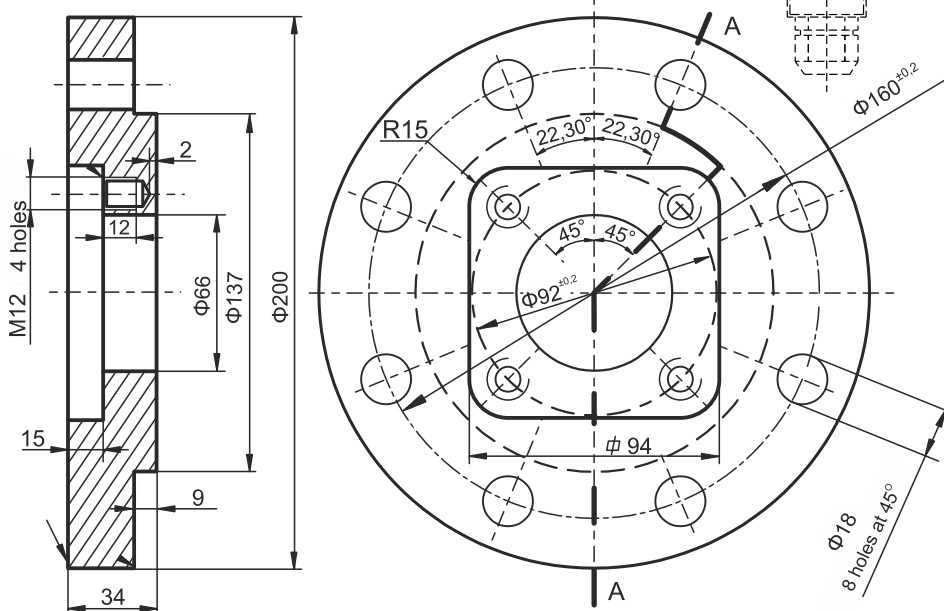

It is possible to order a controller with connector, in accordance with the requirements, e. g. the flange acc. to DIN or ANSI standard.

Reduction flange type ER2-1642

Material St3S steel

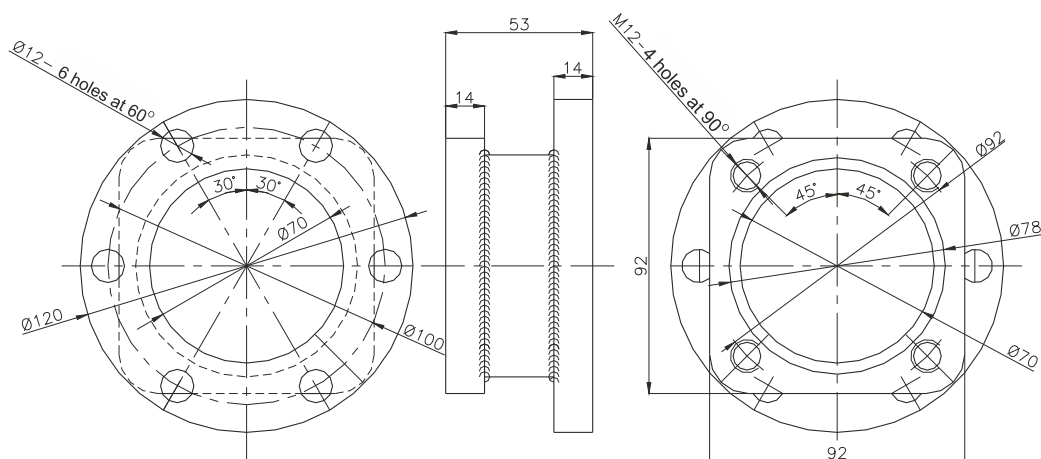

Counter-flange and mounting chamber

Description

The counter-flange and the mounting chamber are the mechanical elements designed for permanent mounting to the tank and which make possible to mount the controller.

The counter-flange allows to mount the controller inside the tank. The mounting chamber is applied for installing on the pipelines and tanks of small dimensions, and also in case when presence of controller inside the tank is not indicated, or possible for example due to steady elements which can be found in a liquid and damage the controller float.

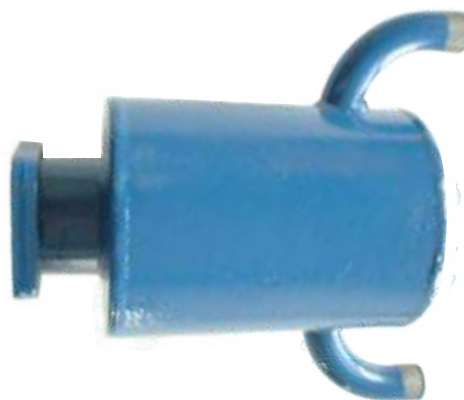

Counter-flange type ER2-1646

Material	St3S steel	(ER2-1646-1)
	316L stainless steel	(ER2-1646-2)

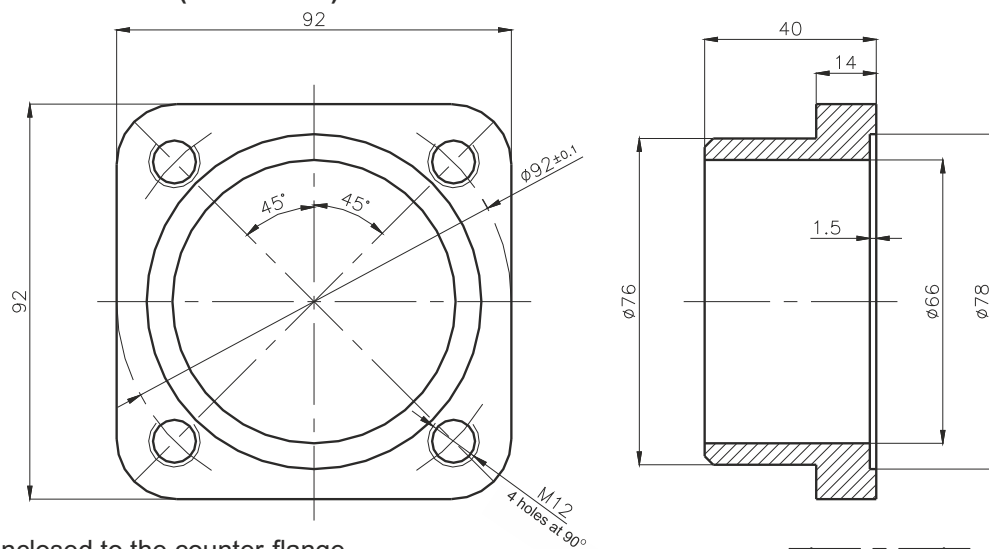

The fixing elements are enclosed to the counter-flange.

Mounting chamber type ER3-1631

Material	boiler tube R35 and St3S steel
Weight	6,5 kg

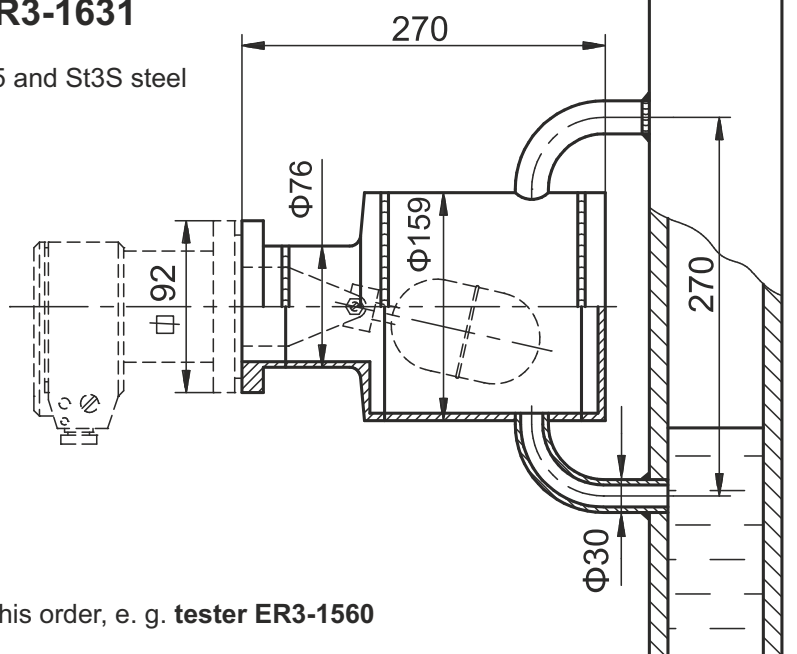

Ordering

One should give the name and type in his order, e. g. **tester ER3-1560**