

Smart temperature transmitter LI-24ALW

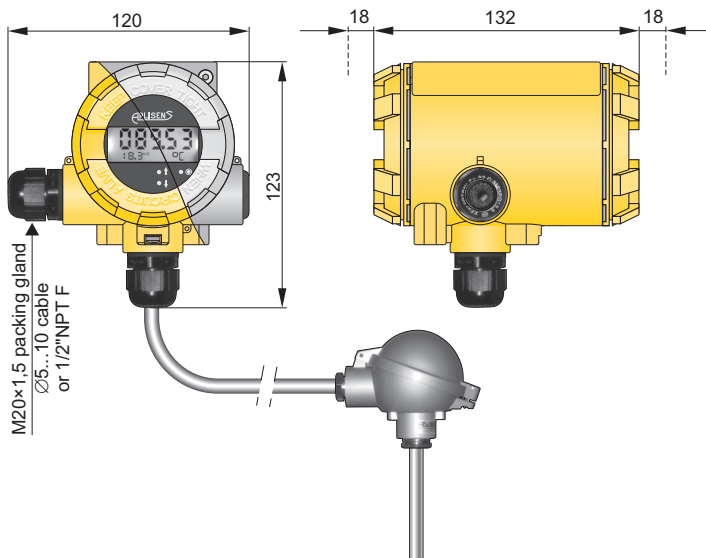

- ✓ Output signal 4...20mA with Hart protocol
- ✓ Galvanic insulation (In, Out)
- ✓ Programmable sensor type
- ✓ Programmable measuring range
- ✓ Thermoresistance line compensation
- ✓ Compensation of thermocouple cold junction
- ✓ Autodiagnostic system
- ✓ Intrinsic safety certificate (ATEX, IECEx)
- ✓ Explosion proof certificate (ATEX, IECEx)
- ✓ Safety version SIL2/SIL3



LI-24ALW with remote mounted temperature sensor

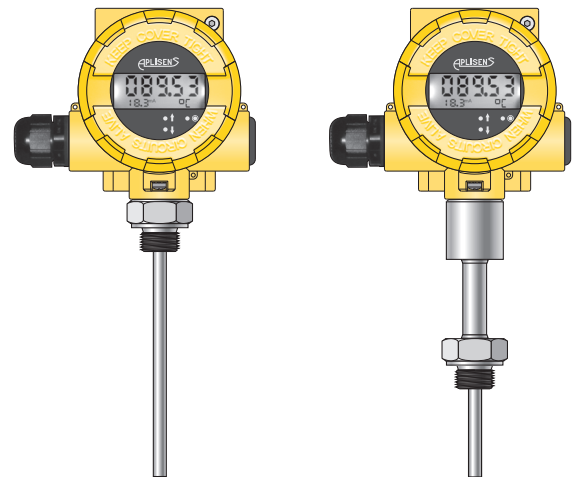

LI-24ALW with direct mounted temperature sensor

Application and function

The temperature transmitter LI-24ALW is applicable to converting resistance of temperature or voltage of thermocouple sensor to standard current signal 4-20mA. The transmitter has two separate channels enabling measurement of temperature difference, average, average with redundancy, max. or min. temperature. Transmitter has compensation of ambient temperature influence and compensation of thermocouple cold junction using internal/external (Pt100) sensor or constant temperature. Most of parameters such as: sensor type, measuring range, current alarm signal when electric circuit is broken, output characteristic correction, user characteristic (60 points) are programmed using PC with HART/USB converter and Aplisens RAPORT 2 configuration software. For request Aplisens can set temperature transmitter parameters like measuring range, type of sensor. Their values are printed on label. Transmitter LI-24/ALW is designed for field use. LI-24ALW can be used with temperature sensors mounted directly in transmitter's casing or with external sensors connected with cable.

Technical data

Input signal	Resistance: Pt100, Ni100 Voltage: K, J, S, B, N, T, R, E
Limit process	-10mV < E < 100mV or -100mV < E < 1000mV 0Ω < R < 400Ω or 0Ω < R < 2000Ω
Min. measuring range	10mV or 10Ω or 10K
Output signal	4 - 20 mA + Hart 13,5*...55 VDC Exia: 13,5*...30 VDC Exd: 13,5*...45 VDC Safety, Safety Exd: 12,5...36 VDC Safety Exia: 12,5...30 VDC
Power supply	*- with display illumination switched on +3V, display backlight can be switched on only during production
Max. wires resistance	500Ω
Alarm signal	3,75mA / 21,5mA (NORMAL) or 3,6 mA / 21 mA (NAMUR NE89) or setting by user
Sensor current	0,42mA Safety: 0,25mA
Galvanic insulation	Optoelectrical
Time constant	0,3s
Additional electronic damping	0..30s
Ambient temperature	-40...+80°C Exia: -40...+80°C Exd: -40...+75°C Safety: -40...+85°C Safety Exia, Safety Exd: -40...+75°C

LI-24ALW/Safety can be programed only with HART protocol. Local buttons allows only to change display settings.

Type of input signals and metrological parameters

RTD sensors			Thermocouples		
Thermal resistance sensors	2, 3 or 4 wires connection		Input impedance	>10MΩ	
Sensor current	~250 μA		Maximum wires resistance	500 Ω (wires + thermocouple)	
Maximum wires resistance	25 Ω		Cold junctions compensation	Internal sensor, external sensor Pt100, constant value	
Sensor type	Basic range (FSO)	Min. range span	Sensor type	Basic range (FSO)	Min. range span
	°C	K		°C	K
Pt100	-200+850	10	B	500+1820	50
Pt200	-200+850	10	E	-150+1000	50
Pt500	-200+850	10	J	-210+1200	50
Pt1000	-200+266	10	K	-150+1372	50
Ni100	-60+180	10	N	-150+1300	50
Cu100	-50+180	10	R	50+1768	50
			S	50+1768	50
			T	-150+400	50
Resistance (resistor, potentiometer)			Internal sensor CJC	-25+75	-
			Voltage		
	Ω	Ω		mV	mV
Measuring range No.1	0+400	10	Measuring range No.1	-10+100	10
Measuring range No. 2	0+2000	10	Measuring range No. 2	-100+1000	10

Electrical diagrams

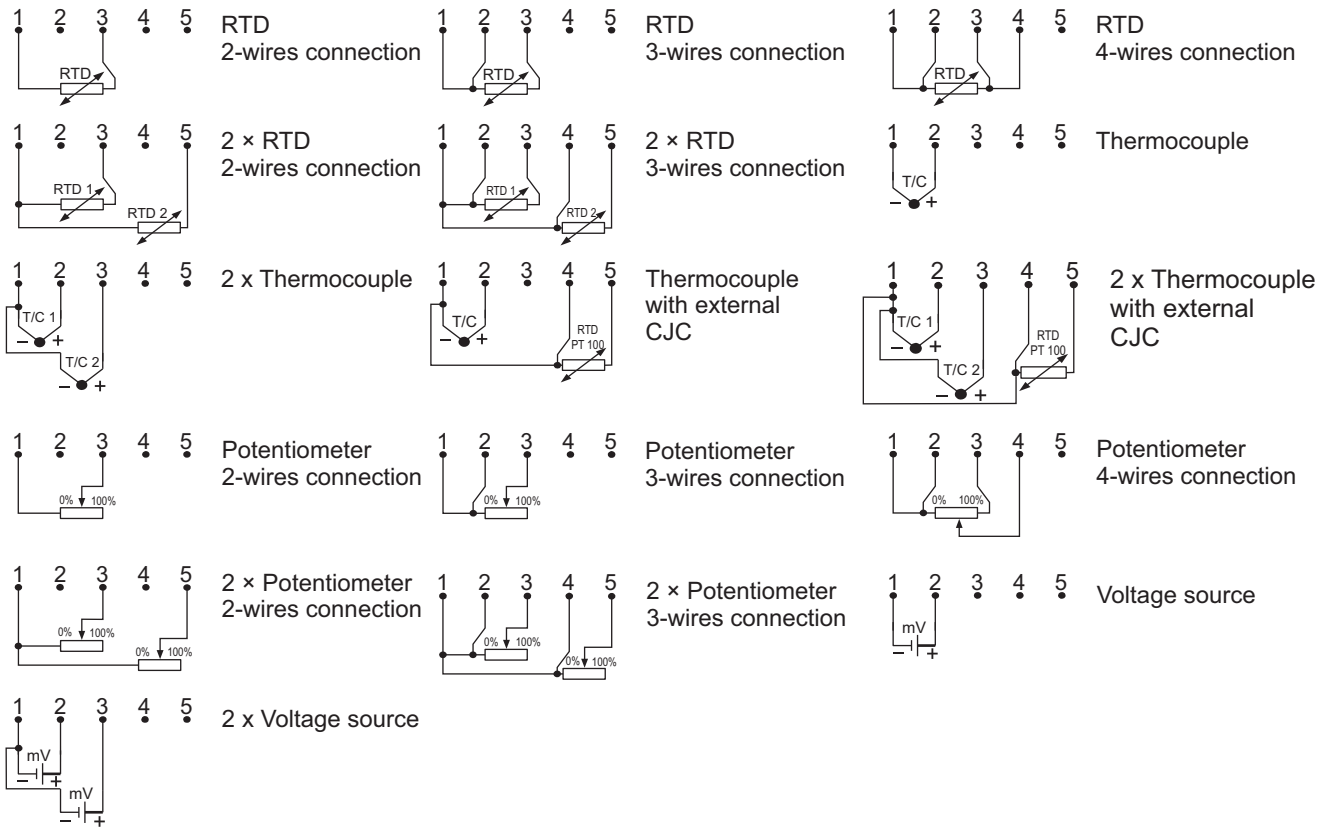

Direct mounted sensors

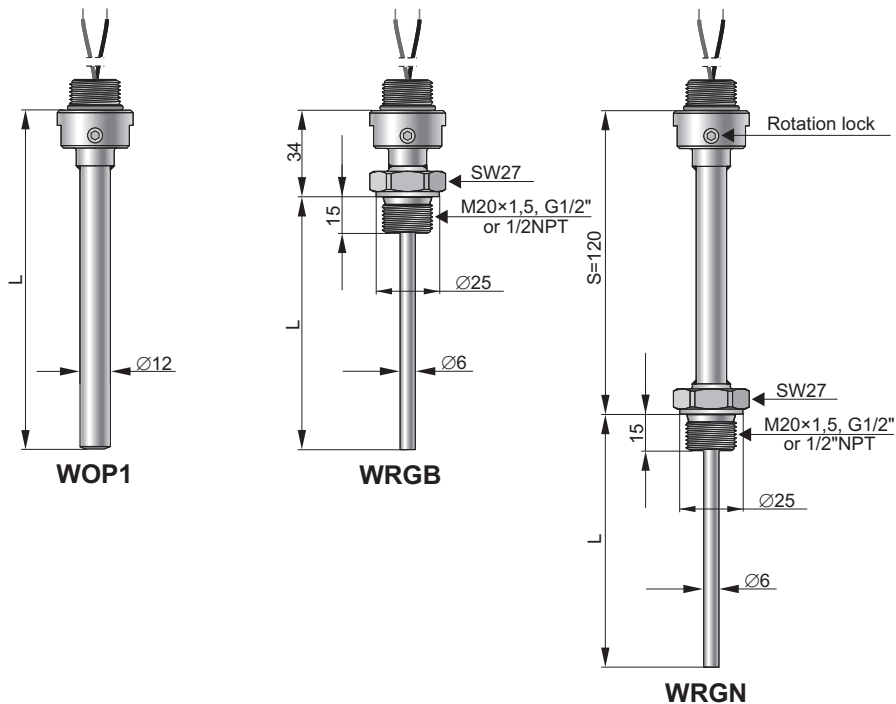

Code	Description	Shield material	Connector material
WRGN, WRGB	Spring-loaded sensors (to use with additional thermowell)	316L (Pt100) Inconel 600 (TC)	316
WOP1	Sensor with integrated thermowell	316L	-

Ordering code

Model	Code	Description
LI-24		Smart temperature transmitter
Versions	/ALW.....	With display, output 4-20mA + Hart
	/ALW/Safety.....	With display, output 4-20mA + Hart Functional Safety certificate according to PN-EN 61508:2010 parts 1 + 7, PN-EN 61511-1:2017-07 + PN-EN 61511-1:2017/A1:2018-03, PN-EN 62061:2008 + PN-EN 62061:2008/A1:2013-06 + PN-EN 62061:2008/A2:2016-01
Certificates, options*	/SS..... /Exia.....	Stainless steel housing II 2(1)G Ex ia [ia Ga] IIC T4/T5/T6 Gb II 1/2G Ex ia IIC T4/T5/T6 Ga/Gb (with direct sensor) Safety version: II 2(1)G Ex ia [ia Ga] IIC T4 Gb Ex ia [ia Ga] IIC T4/T5/T6 Gb Ex ia IIC T4/T5/T6 Ga/Gb (with direct sensor) Safety version: Ex ia [ia Ga] IIC T4 Gb IECEX
	/Exia (Da).....	II 2(1)G Ex ia [ia Ga] IIC T4 Gb II 1D Ex ia IIIC T105°C Da I M1 Ex ia I Ma (with 316ss case) Ex ia [ia Ga] IIC T4 Gb Ex ia IIIC T105°C Da Ex ia I Ma (with 316ss case) IECEX
	/Exd.....	With remote sensor: II 2(1)G Ex db [ia Ga] IIC T5/T6 Gb II 2(1)D Ex tb [ia Da] IIIC T100°C/T85°C Db I M2 Ex db [ia Ma] I Mb (with 316ss case) With direct sensor WO.../WR...: II 2G Ex db IIC T**/T5/T6 Gb II 2D Ex tb IIIC T*/T100°C/T85°C Db I M2 Ex db I Mb (with 316ss case) Safety version: II 2G Ex db IIC T**/T5/T6 Gb II 2D Ex tb IIIC T*/T100°C/T85°C Db I M2 Ex db I Mb (with 316ss case) With remote sensor: Ex db [ia Ga] IIC T5/T6 Gb Ex tb [ia Da] IIIC T100°C/T85°C Db Ex db [ia Ma] I Mb (with 316ss case) With direct sensor WO.../WR...: Ex db IIC T**/T5/T6 Gb Ex tb IIIC T*/T100°C/T85°C Db Ex db I Mb (with 316ss case) Safety version: Ex db IIC T**/T5/T6 Gb Ex tb IIIC T*/T100°C/T85°C Db Ex db I Mb (with 316ss case) IECEX
	/IP67..... /US.....	Protection class IP67 Electrical and sensor connection "NPTF"
Type of measuring element	/.....	Type of measuring element according to tables from page IX/7
Measuring set range	/.....	Measuring range
Sensor type (optionally)	/ (none)	Without sensor
	/code of direct sensor	Direct mounted sensor according to below table

Type of sensor	WRGN.....	Spring loaded sensor with threaded process connection, neck S=120mm, additional TW required.
	WRGB.....	Spring loaded sensor with threaded process connection, additional TW required.
	WOP1.....	Sensor with integrated TW.
Special version	/Exia.....	Intrinsic safe version
	/Exd.....	Explosion proof version
Length of sensor	/L=...mm	Required length of immersion [mm]
Neck extension	/S=...mm	Required length of neck [mm] (if different than standard)
Process connection		Thread type
Type of measuring element		Type of measuring element
Sensor material		Sensor material (if different than standard)
Connection thread between sensor and transmitter		Thread between sensor and transmitter