

Flanged seals with extended diaphragm S-T

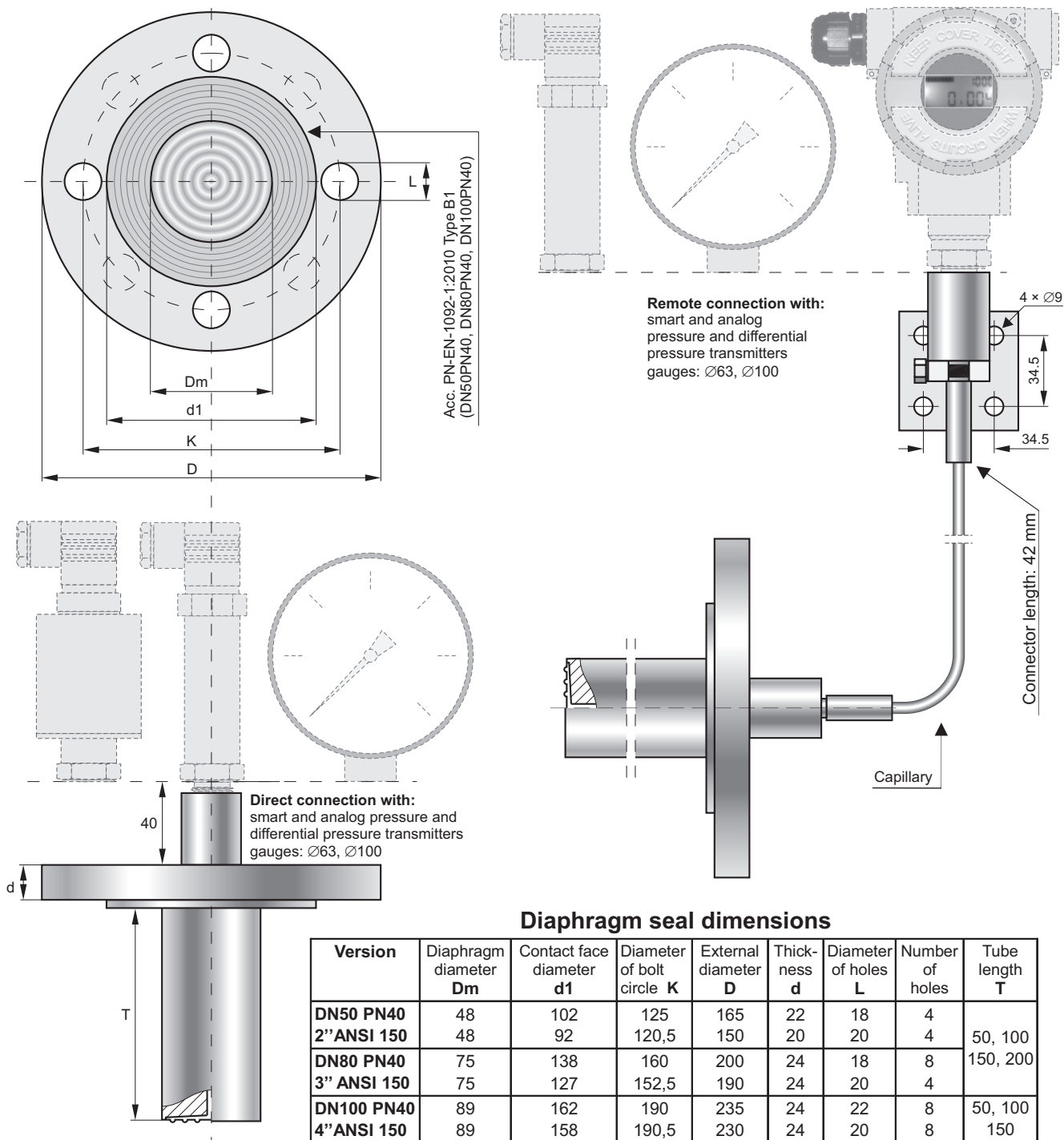

Application

The diaphragm seal is a pressure-transmitting, diaphragm-type device. The pressure signal is sent to the cooperating pressure measuring device (pressure transmitter, pressure gauge) through manometric liquid filling the space between the separating diaphragm of the seal and the pressure measuring device. The diaphragm seal task is to isolate the pressure measuring device from damaging impacts caused by either medium or installation:

- low or high temperature, increased viscosity, impurities;
- tendency to crystallisation on the tank walls;
- vibrations of the installation (remote diaphragm seal).

The flanged diaphragm seal with extended diaphragm is typically applied to measure the pressure or level of the media in a multi-walled tank, where the separating diaphragm should be placed close to the inner wall of the tank.

**Recommended minimum measuring range (bar),
depending on the type of the set: pressure measuring device - diaphragm seal**

Pressure measuring device	Seal type	Wykonanie separatora		
		DN50 / 2"	DN80 / 3"	DN100 / 4"
Smart transmitters*	direct	0,1	0.1	0.1
	remote (2 m)	6	0.5	0.25
PCE-28	direct	0.1	0.1	0.1
	remote (2 m)	2	0.5	2.5
Ø63 manometer	direct	1	1	1
	remote (2 m)	2.5	2.5	1
Ø100 manometer	direct	1	1	1
	remote (2 m)	2.5	2.5	1

* The ranges given in the table for smart transmitters should be taken as set ranges

Recommendations

The essential metrological problem at diaphragm seals operational use is an absolute thermal zero error, resulting from the thermal expansion of the manometer liquid. The expansion effect must be compensated for with the separating diaphragm flexibility.

To minimise this effect, it is advisable to:

- use capillaries as short as possible, in this way the volume of manometer liquid will be reduced
- (maximum capillary length for DN50 / 2" is 5m);
- use the greater diameter seals, in order to maximise the separating diaphragm flexibility;
- locate the capillaries in the places, in which the temperature fluctuations will be minimal.

Zero error from ambient temperature change - diaphragm seal with a 100 mm of tube

Diaphragm seal type	Absolute zero error per 10°C for the diaphragm seal		
	DN50 / 2"	DN80 / 3"	DN100 / 4"
direct	2 mbar	0.6 mbar	0.4 mbar
remote (2 m capillary)	10 mbar	2 mbar	1 mbar

An additional zero error, resulting from temperature fluctuations in a medium, depends on the temperature gradient in the oil-based diaphragm sealing system. The error value is, in any case, significantly smaller than the error value shown in the table.

Temperature range of measured medium

Remote diaphragm seal			Direct diaphragm seal
Manometric liquid	Underpressure measurements	Overpressure measurements	
very high temperature (DH)	max. 200°C for p > 0,05 bar ABS	15...380°C	-30...150°C
high temperature (DC)	max. 250°C for p > 0,1 bar ABS	-10...315°C	
low temperature (AK)	not recommended for measurement of pressures < 0,2 bar ABS	-60...200°C	

Note: When operating with an ambient temperature of < 0°C, heating of capillaries filled with DC or DH fluid is recommended.

Special versions

- Other standards DIN and ANSI
- Direct diaphragm seal for medium temp. over 150°C
- Others

Maximum pressure for PN40 – 40 bar

Maximum pressure for ANSI 150 – 150 psi

Material of diaphragm, tube and flange: 316Lss

Important:

- standard outlet capillary from flange:
 - direct mounted diaphragm seal - axial
 - remote mounted diaphragm seal - axial
 - other configuration available on request

Ordering procedure

direct diaphragm seal:

pressure measuring device / S-T – DN..... / T = mm / spec. ver. (description)

remote diaphragm seal:

pressure measuring device / S-TK – DN..... / T = mm / K = m / / spec. ver. (description)

Transmitter or gauge
– see the code in the appropriate catalogue sheet

Seal version

Tube length

Capillary length

Mounting of capillary:
AX - axial (standard version)
RD - radial (on request)