

Intrinsically safe power supply and isolator ZS-30/1Ex

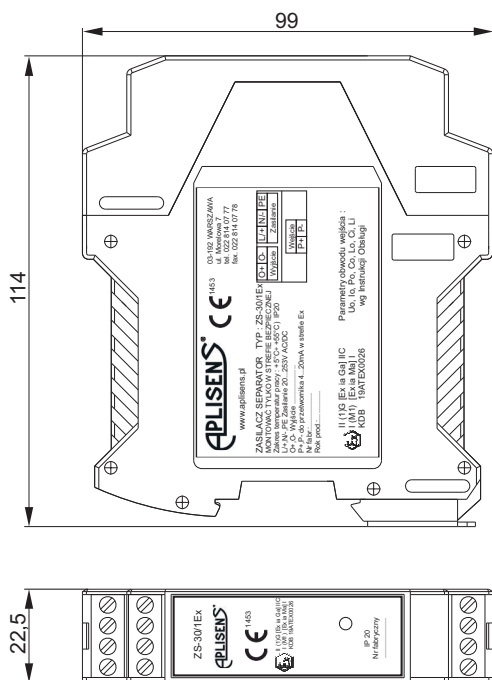

- ✓ I (M1) [Ex ia Ma] I
II (1)G [Ex ia Ga] IIC
- Ex-rated intrinsically safe**
- ✓ **Full galvanic separation of circuits (IN-OUT, IN-SUPPLY, OUT-SUPPLY)**
- ✓ **Digital calibration of measurement chain IN-OUT**
- ✓ **Accuracy 0,1%**
- ✓ **Universal power supply 20...253V AC/DC**
- ✓ **Casing can be mounted on a standard rail (TS35, TS32)**



Application and function

The ZS-30/1Ex power supply and isolator is a partially intrinsically safe device with an external (input) intrinsically safe circuit.

The ZS-30/1Ex is designed to supply power to intrinsically safe transmitters used in a hazardous area, with a 4...20 mA signal in a two-wire transmission, and to transform that signal through a galvanic separation circuit into one of the standard signals used in automatic control: 4...20mA, 0...20mA; 0...5mA; 0...10V, 0...5V, 1...5V, 2...10V.

The supply voltage of the intrinsically safe input circuit of the standard version of the ZS-30/1Ex is 24 V DC. IN, OUT and SUPPLY circuits are galvanic separated.

ZS-30/1Ex has universal power supply 20..253V AC/DC.

Electric diagram

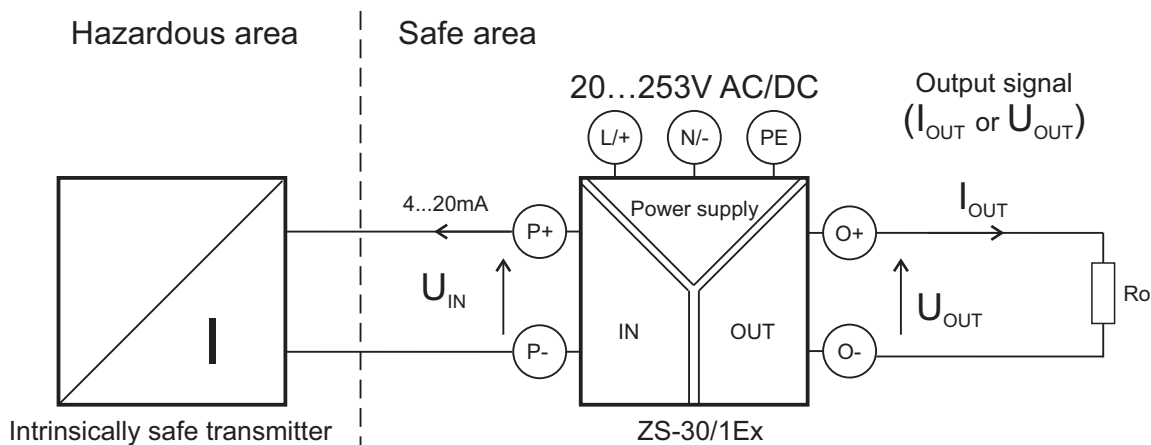

Technical parameters

• Input parameters

Supply voltage of the input circuit U_{IN}	24V
Maximum voltage on the terminals of the input circuit (terminals <P+>, <P->)	25,2V
Work supply voltage on the terminals of the input circuit (terminals <P+>, <P->)	22,5V
Min. input voltage (for $I_{IN}=20\text{mA}$) after connecting transmitter with output signal 4...20mA	$U_{IN20} = U_{IN} \times 0,65$
Maximum shorting current of input circuit (terminals <P+>, <P->)	(27...35)/ 100 mA

• Output parameters

Output signal (I_{OUT} or U_{OUT})	Output load resistance R_o
4...20mA (standard version)	0...500 Ω
0...20mA	0...500 Ω
0...5mA	0...2k Ω
0...5V, 1...5V, 0...10V, 2...10V	$\geq 10\text{k}\Omega$

• Metrological parameters

Accuracy	$\leq 0,1\%$
Effect of load resistance fluctuations	$\leq \pm 0,05\%$
Effect of temperature fluctuations	$\leq \pm 0,01\%/^{\circ}\text{C}$
Time constant	ok. 0,05s (special version: 0,1...1s)

• Separation, power supply

Circuit separation	all circuits are galvanic separated
Power supply	20...253 V AC/DC
Power consumption	$\leq 2\text{W}$
Test voltage between circuits	1,5kV 50Hz acc. PN-EN 60079-11, PN-EN 61010-1
Supply current (starting)	max. 0,6 A (for $U_{SUP} = 20\text{V DC}$)

• Ambient temperature

5...+55 $^{\circ}\text{C}$

• Ingress protection rating

IP20 acc. PN-EN 60529

• Weight

< 0,150 kg

• Dimensions

(114 × 99 × 22,5)mm

• Relative humidity

30...85%

Ordering procedure

Standard version ($U_{IN} = 24\text{V}$, $I_{OUT} 4...20\text{mA}$): **ZS-30/1Ex**

Special version: **ZS-30/1Ex /**

Output signal 