

Side Mounting Float Switch

WORKING PRINCIPLE

The reed switch relies on two basic scientific principles namely: buoyancy and magnetism.

Buoyancy causes the float (which contains a magnet) to rise with the liquid and magnetism helps open and close the switch.

A change in liquid levels raises or lowers the float up or down. The end of the pivot arm (non float side) contains a permanent magnet that can repel the switch magnet (inside the stationary 'stem' of the entire structure).

When the float magnet moves close to the switch's stationary stem, the float magnet repel the switch magnet which either opens or closes the Electrical circuit.

FEATURES

The side mounted float level sensor (FF series) are manufactured specifically for horizontal mounting on tanks or vessels. They work well as high or low level controls.

1. Both Micro-Switch types and Reed Switches are available. The MicroSwitch type is usable even at ambient temperatures of 100° C maximum.
2. Mounting flanges are custom-made. (JIS, DIN,ANSI).
3. A wide variety of floats for different solution's specific gravities (S.G.) are available.
4. Wetted parts material ranges from plastics, stainless steel, anti-corrosive and explosion proof types.

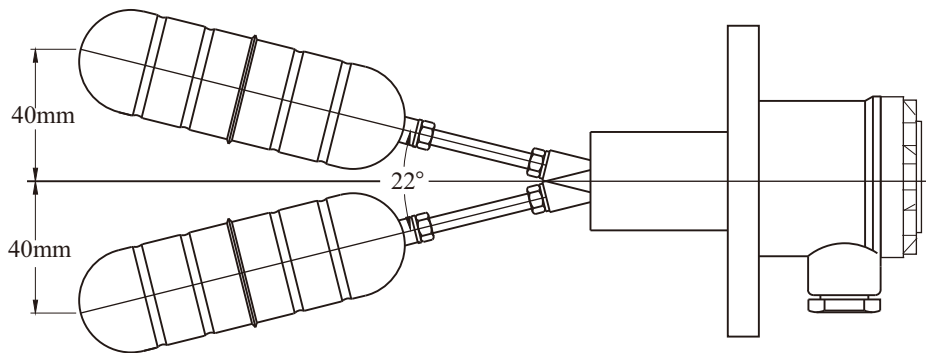

WIRING

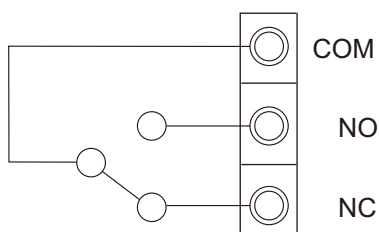

REED SWITCH ---- 1A, 30W 220Vac/200Vdc (FF20, 45, 55, 8□)
MICRO SWITCH ---- 5A/250Vac

CONFIGURATION DIAGRAMS

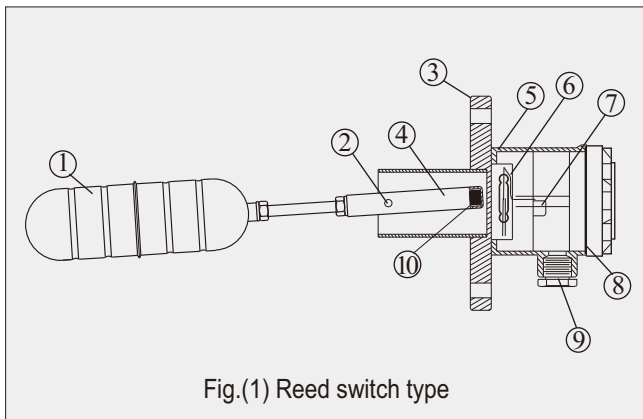

Fig.(1) Reed switch type

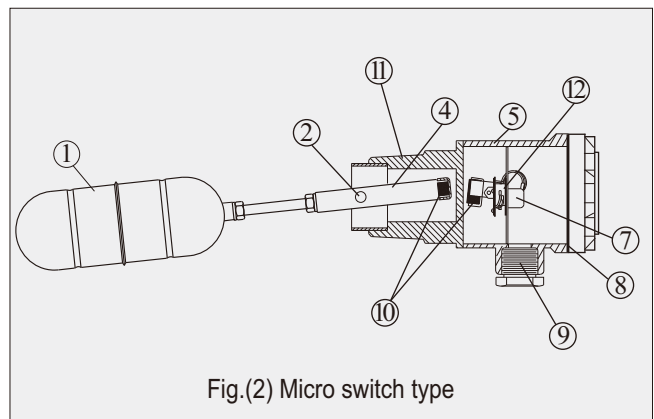
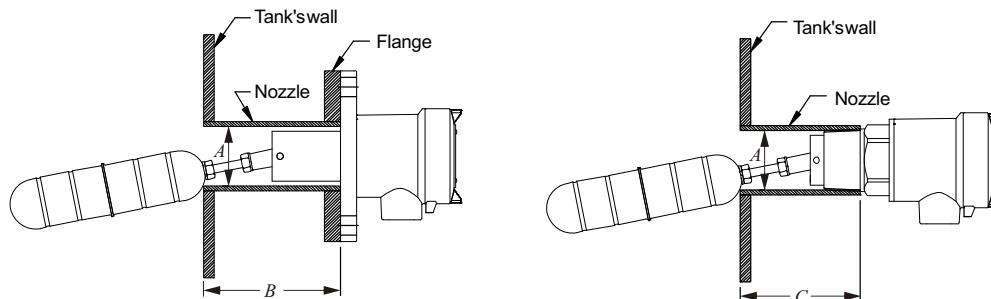

Fig.(2) Micro switch type

- 1. Float 4. Pivot 7. Terminal 10. Magnet
 - 2. Shaft 5. Housing 8. O-ring 11. Screw
 - 3. Flange 6. Reed Switch 9. Conduit 12. Microswitch
- Conduit/Connection

Nozzlelength



The length of the nozzle has to be comply with the pipe diameter. If the length of nozzle is too long It will affect the switching movement. The suggested maximum length of the nozzle is listed as below chart:

(Unit: mm)

Pipe inner diameter (A)	Float Ø41X150L		Float Ø50X150L		Float Ø75X120L	
	Flange connection max.(B)	Screw connection (C) max.	Flange connection (B) max.	Screw connection (C) max.	Flange connection (B) max.	Screw connection (C) max.
45	102	91	⊕	⊕	⊕	⊕
50	103	92	102	91	⊕	⊕
55	105	94	103	92	⊕	⊕
60	108	97	106	95	⊕	⊕
65	112	101	107	96	⊕	⊕
70	122	111	110	99	⊕	⊕
75	135	124	114	103	106	95
80	148	137	124	113	107	96
85	161	150	137	126	109	98
90	170	159	150	139	112	101
95	186	175	163	152	115	104
100	199	188	169	158	119	108
105	212	201	188	177	125	114
110	225	214	201	190	136	125
115	⊙	⊙	214	203	149	138
120	⊙	⊙	⊙	⊙	162	151
125	⊙	⊙	⊙	⊙	174	163
130	⊙	⊙	⊙	⊙	⊙	⊙

⊕: Float dia is larger than the nozzle dia so sensor cannot be insert.
 ⊙: Nozzle length is not limited.

SPECIFICATIONS



MODEL \ SPEC.	Operating Temp.	Electrical Contact	Contact Capacity	Contact Element	Housing Spec.	Applicable S.G.
FF40DFM	-20°C~100°C	SPDT(1C)	5A/250Vac	Microswitch	Aluminum Alloy IP65	0.55
FF45DFM	-40°C~200°C	SPDT(1C)	1A, 60W 220Vac/200Vdc	Reed Switch	Aluminum Alloy IP65	0.55
FF50DFM	-20°C~100°C	SPDT(1C)	5A/250Vac	Microswitch	Aluminum Alloy IP65	0.55
FF55DFM	-40°C~200°C	SPDT(1C)	1A, 60W 220Vac/200Vdc	Reed switch	Aluminum Alloy IP65	0.55
FF70/71BHM	-20°C~100°C	SPDT(1C)	3A/250Vac	Microswitch	SUS316 Ex d, Ex tb	0.25
FF70/71CFM	-20°C~100°C	SPDT(1C)	3A/250Vac	Microswitch	SUS316 Ex d, Ex tb	0.65
FF70/71DFM	-20°C~100°C	SPDT(1C)	3A/250Vac	Microswitch	SUS316 Ex d, Ex tb	0.55
FF73GLO	-20°C~100°C	SPDT(1C)	3A/250Vac	Microswitch	SUS316 Ex d, Ex tb	0.7
FF75DFM	-20°C~100°C	SPDT(1C)	3A/250Vac	Microswitch	SUS316 Ex d, Ex tb	0.55
FF90CLO 	-20°C~100°C	SPDT(1C)	5A/250Vac	Microswitch	Aluminum Alloy IP65	0.65

※ Above-mentioned models are approved by class societies : DNV 、 LR 、 GL 、 BV 、 ABS 。

MODEL \ SPEC.	Operating Temp.	Electrical Contact	Contact Capacity	Contact Element	Housing Spec.	Applicable S.G.
FF30A3Q	-20°C~100°C	SPST(1A)	1A, 50W 240Vac/200Vdc	Reed Switch	SUS304 IP65	0.65
FF62DFM	-40°C~350°C	SPDT(1C)	5A/250Vac	Microswitch	Aluminum Alloy IP65	0.55
FF80EFM	-20°C~80°C	SPDT(1C)	1A, 30W 220Vac/200Vdc	Reed switch	PC IP65	0.60
FF81E	-20°C~80°C	SPDT(1C)	1A, 30W 220Vac/200Vdc	Reed switch	—	0.60

SQUARE FLANGE & TEST ACCESSORIES

► FF90CLO

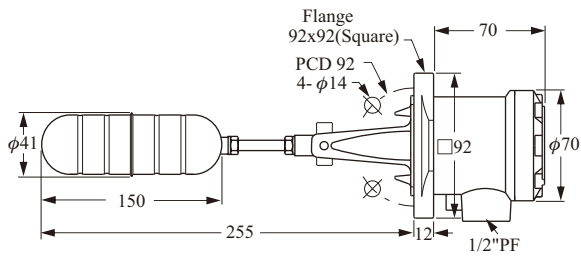

1. Housing material: Aluminum (IP65)
2. Suitable S.G.: >0.65
3. Operation temp.: -20~100°C
4. Contact mode: SPDT(1C)
5. Contact rating: 5A/250Vac
6. Operation pressure: 15kg/cm²
7. Wetted parts: SUS304
8. Weight: (approx.) 1.2 kg

Drill Hole

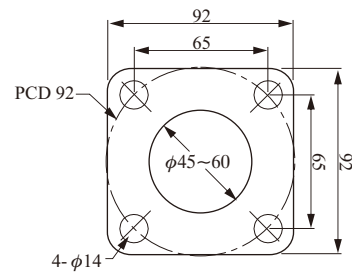

Test Board (Optional)

Material: SS41

Please weld test board with level instrument.
Without level dropping, level instrument can be checked regularly if functions well.

Check list

- Check if mechanical parts of level switch function well?
- Check if float functions well?

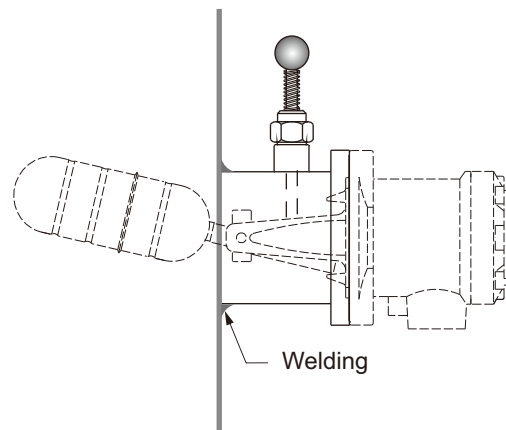
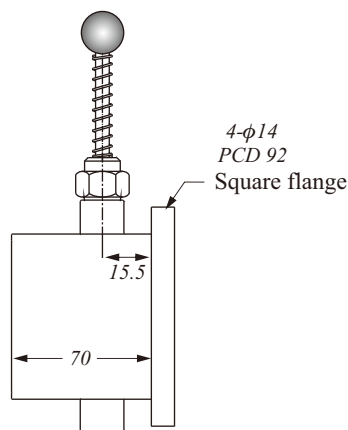
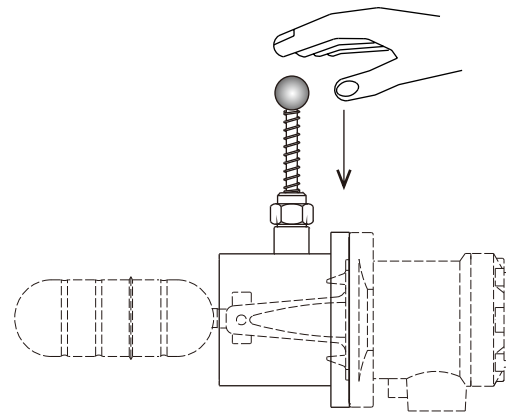

IMPORTANCE FOR INSTALLATION

1. SUS304/SUS316 materials are not available for corrosive application.
2. The cable duct(s) must face downward to prevent moisture seeping in.
3. The float and extension rod must be inserted into the bin completely.
4. Check the liquid's S.G. level before installation.
5. The mounting hole must be larger than the external diameter of the float. (Please refer to p2)
6. Don't mount the devices near the bin's inlet or outlet.

Typical Positioning

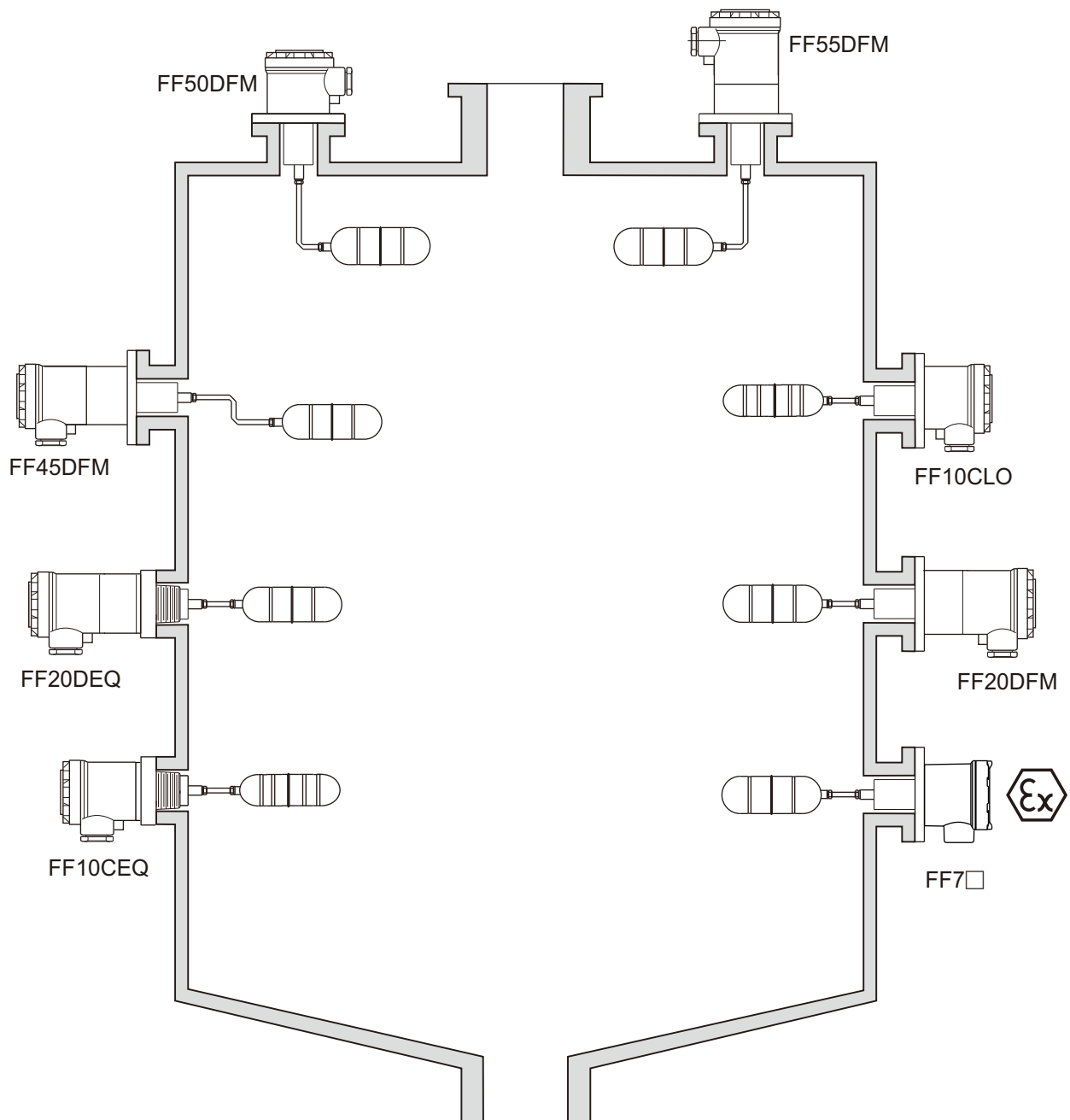

MODEL NUMBER / ORDER CODE COMPARISON TABLE

Model Number	Order Code
FF10BHM	FFX10000-A1HAKB540B
FF10CEM	FFX10000-A1HAKB140C
FF10CEQ	FFX10000-A1HAAB101C
FF10CLO	FFX10000-A1HAZ0000C
FF10DFM	FFX10000-A1HAKB240D
FF10DFQ	FFX10000-A1HAAB201D
FF15HEQ	FFX10000-A2ZAAB101F
FF12CEM	FFX10000-B1HAKB140C

Model Number	Order Code
FF70CEQ	FFX1001C-A1MAAB101C
FF70CFM	FFX1001C-A1MAAB240C
FF70DFM	FFX1001C-A1MAAB240D
FF70DFQ	FFX1001C-A1MAAB201D
FF71BHM	FFX1001C-A1MAKB540B
FF71CEM	FFX1001C-A1MAKB140C
FF71CFM	FFX1001C-A1MAKB240C
FF71DFM	FFX1001C-A1MAKB240D
FF73CLO	FFX1001C-A6MAZ0000C
FF73GLO	FFX1001C-A6MAZ0000G
FF74DFM	FFX1001C-A5MAKB240D
FF75DFM	FFX1001C-A4MAKB240D

FF20BHM	FFX10200-A1HAKB540B
FF20CEM	FFX10200-A1HAKB140C
FF20CEQ	FFX10200-A1HAAB101C
FF20DFM	FFX10200-A1HAKB240D
FF20DFQ	FFX10200-A1HAAB201D
FF20DLO	FFX10200-A1HAZ0000D

FF90CLO	FFX10000-A6HAZ0000C
FF30A3Q	FFX10100-A70AAA901A
FF62DFM	FFX10800-A1HAKB240D
FF80EFM	FFX10000-A3GAKB240E18
FF81E	FFX10000-A30ABJ282E18

FF40DFM	FFX10000-A5HAKB240D
FF45DFM	FFX10200-A5HAKB240D
FF50DFM	FFX10000-A4HAKB240D
FF55DFM	FFX10200-A4HAKB240D

ORDER INFORMATION



FFX1 ⑤⑥⑦⑧-⑨⑩⑪⑫⑬⑭⑮⑯⑰⑱⑲⑳㉑㉒㉓㉔

⑤ ⑥ Model

- 00: Standard
- 01: Economy
- 02: Hi-temperature
- 08: Super Hi-temperature

⑦ ⑧ Certification

- | | | |
|----------------|--------------|---------------|
| 00: None | D0: GL | F1: LR+ATEX |
| 1C: ATEX-Ex d | E0: BV | B7: DNV+NEPSI |
| 2C: IECEx-Ex d | F0: LR | C7: ABS+NEPSI |
| 5C: TS-Ex d | B1: DNV+ATEX | D7: GL+NEPSI |
| 7C: NEPSI-Ex d | C1: ABS+ATEX | E7: BV+NEPSI |
| B0: DNV | D1: GL+ATEX | F7: LR+NEPSI |
| C0: ABS | E1: BV+ATEX | |
| D0: GL | | |

⑨ ⑩ Constrution

- | | |
|--------------------|---|
| A1: Standard | B1: Standard with dual switch |
| A2: Mini | B4: Vertical with dual switch |
| A3: Anti-Corrosive | B5: Doule angle with dual switch |
| A4: Vertical | B6: Square flange & test accesries with dual switch |
| A5: Doule angle | |
| A6: Square flange | |
| A7: Small | |

⑪ Housing

- 0: None
- H: H type(Aluminum) 1/2"PF-f 70*70
- M: M type(For Certification only)
- G: G type(For Anti-corrosive only)
- Z: SUS type(For Mini only)

Connection

- | | | | |
|-------------------------|------------|-------------------------|--------------------------|
| ⑫ ⑬ | ⑭ ⑮ | ⑯ ⑰ | |
| Flange item | 00: None | 00: None | 42: 10kg/cm ² |
| AK: JIS-FF | A9: 1-1/4" | 01: PT male | 48: 150Lbs |
| AN: ANS-RF | B1: 1-1/2" | 03: PF male | 49: 300Lbs |
| AS: DIN-FF | B2: 2" | 05: BSP male | 57: PN 10 |
| AZ: Square flange 92x92 | B4: 2-1/2" | 07: NPT male | 58: PN 16 |
| | B5: 3" | 13: GAS male | 82: P1.5 male |
| Thread item | E1: DN40 | 40: 5kg/cm ² | |
| AA: JIS | E2: DN50 | | |
| AB: ISO | E3: DN65 | | |
| AC: ANSI | E4: DN80 | | |
| AD: DIN | J2: M20 | | |

(Next page)

ORDER INFORMATION

FFX1 ⁰⁵ ⁰⁶ ⁰⁷ ⁰⁸ - ⁰⁹ ¹⁰ ¹¹ ¹² ¹³ ¹⁴ ¹⁵ ¹⁶ ¹⁷ ¹⁸ ¹⁹ ²⁰ ²¹ ²² ²³ ²⁴

¹⁸ **Float type**

- A: $\phi 32.5 \times 68$, 15kg/cm² 0.65S.G.
- B: $\phi 75 \times 120$, 10kg/cm² 0.25S.G.
- C: $\phi 41 \times 150$, 15kg/cm² 0.65S.G.
- D: $\phi 50 \times 150$, 30kg/cm² 0.55S.G.

- E: $\phi 44 \times 50$ (PP), 5kg/cm² 0.6S.G.
- F: $\phi 41 \times 100$, 15kg/cm² 0.8S.G.
- G: $\phi 41 \times 125$, 15kg/cm² 0.7S.G.

¹⁹ ²⁰ **Wetted parts**

- MA: SUS304
- MB: SUS316
- MC: SUS316L
- 18: PP

²¹ ²² ²³ ²⁴ **Length**

Code	Probe Length
0000	Standard
0250~0800	250~800mm
0270~1000	270~1000mm
0155~0600	155~600mm