

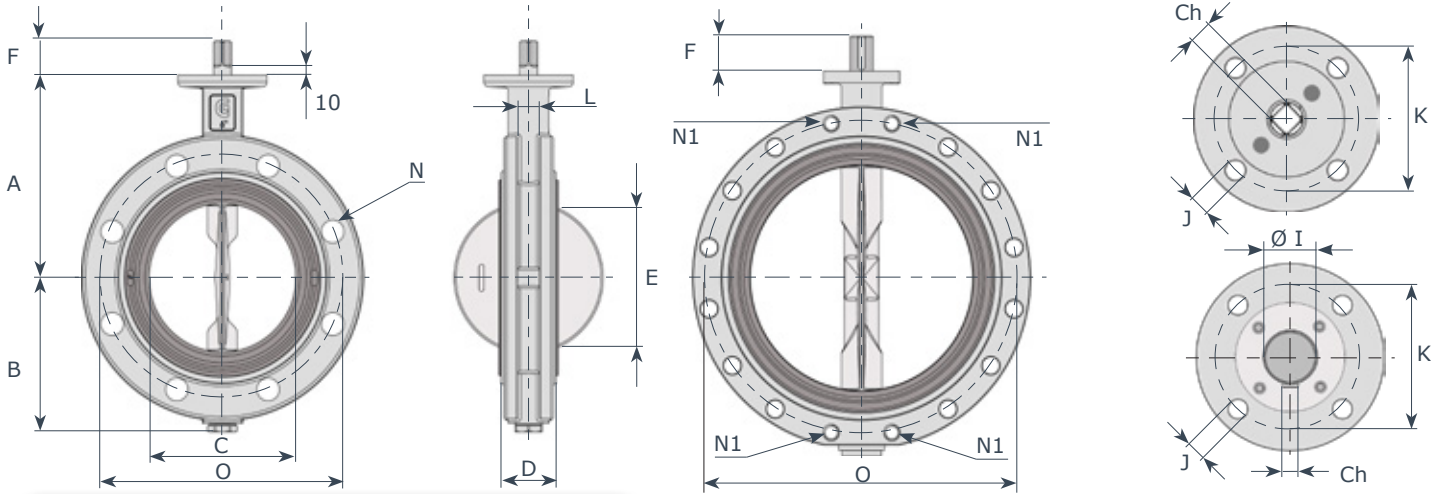

BFKI - Double Flange



Upper flange - ISO 521

DN 80 - 150	F07 - 4 holes	DN 350 - 400	F12 - 4 holes
DN 200 - 300	F10 - 4 holes	DN 450	F14 - 4 holes
		DN 500 - 600	F16 - 4 holes

Note: in case of ANSI150 flanges, threading can be 16"±24" ANSI B1.1-8 UNC2B

DN	"	A	B	C	D	E	F	Ø I	Ch	K	J	L	PN 6				PN 10				PN 16				ANSI 150				Kg.
													N	N1	n.	O	N	N1	n.	O	N	N1	n.	O	N	N1	n.	O	
80	3	158	110	81	46	67	34	14	11	70	9	14	18	--	4	150	18	--	8	160	18	--	8	160	18	--	4	152.4	6.5
100	4	173	128	101	52	87	34	16	11	70	9	16	18	--	4	170	18	--	8	180	18	--	8	180	18	--	8	190.5	8
150	6	202	155	150	56	140	34	18	14	70	9	18	18	--	8	225	22	--	8	240	22	--	8	240	22	--	8	241.3	12
200	8	240	190	200	60	191	38	22	17	102	11	22	18	--	8	280	22	--	8	295	22	--	12	295	22	--	8	298.4	20
250	10	270	220	250	68	241	38	30	22	102	11	30	18	--	12	335	22	--	12	350	25	--	12	355	25	--	12	361.9	30
300	12	300	247	298	78	289	38	30	22	102	11	30	22	M20	12	395	22	M20	12	400	28	M24	12	410	25	--	12	431.8	46
350	14	330	285	341	78	332	60	35	10	125	14	35	22	--	12	445	22	--	16	460	28	--	16	470	28	--	12	476.2	65
400	16	355	310	390	102	376	60	40	12	125	14	40	22	M20	16	495	25	M24	16	515	30	M27	16	525	30	M27	16	539.7	85
450	18	400	343	444	114	430	60	45	12	140	18	45	22	M20	16	550	25	M24	20	565	30	M27	20	585	30	M27	16	577.8	120
500	20	422	375	495	127	479	60	45	12	165	22	45	22	M20	20	600	25	M24	20	620	33	M30	20	650	30	M27	20	635.0	180
600	24	495	460	595	154	575	75	60	18	165	22	60	25	M24	20	705	30	M27	20	725	36	M33	20	770	36	M33	20	749.3	270

BVKX - Wafer BLKX - Lug

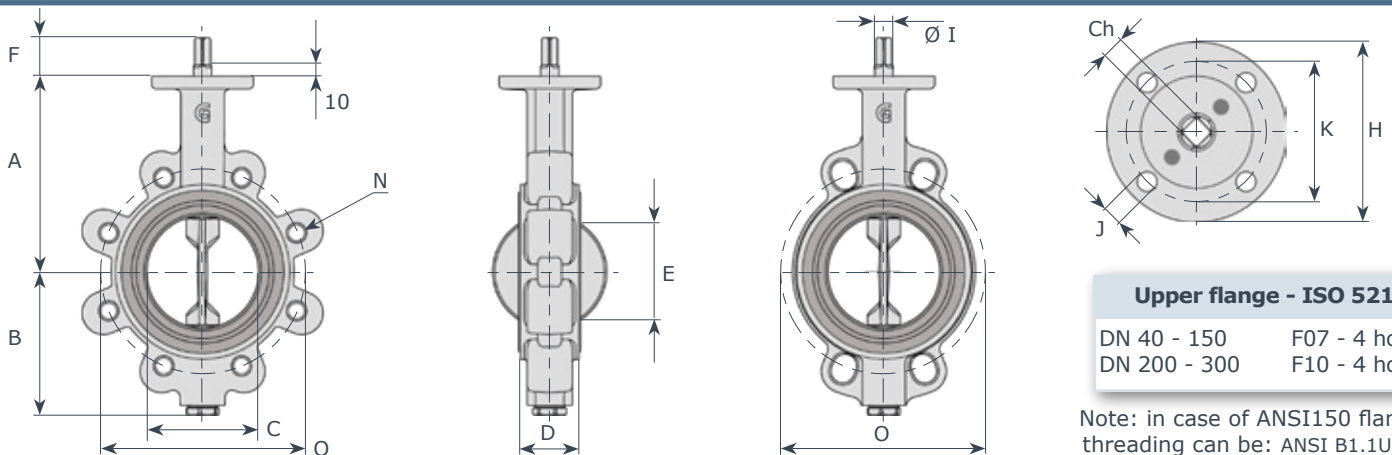

Upper flange - ISO 521

DN 40 - 150	F07 - 4 holes
DN 200 - 300	F10 - 4 holes

Note: in case of ANSI150 flanges, threading can be: ANSI B1.1UNC2B

DN	"	A	B	C	D	E	F	Ø I	Ch	H	K	J	PN 25			Kg.	
													N	n.	O	wafer	lug
50	2	138	81	55	43	35	34	14	11	90	70	9	M16	4	125	2.8	3.7
65	2 ^{1/2}	144	98	68	46	50	34	14	11	90	70	9	M16	8	145	3.7	5.3
80	3	158	110	81	46	67	34	14	11	90	70	9	M16	8	160	4	6.1
100	4	173	128	101	52	87	34	16	11	90	70	9	M20	8	190	6	8.1
125	5	186	140	126	56	113	34	18	14	90	70	9	M24	8	220	7.2	9.7
150	6	202	155	150	56	140	34	18	14	90	70	9	M24	8	250	9.5	11.8
200	8	240	190	200	60	191	38	22	17	125	102	11	M24	12	310	16	29
250	10	270	220	250	68	241	38	30	22	125	102	11	--	--	370	25	--

PD Series - Torque values - Nm - safety factor excluded

Seat body NBR/EPDM				fluid $_2\text{O} - 20^\circ\text{C}$			
working pressure BAR							
DN	0	6	10	DN	0	6	10
80	5	7	11	200	47	58	90
100	8	12	24	250	89	100	115
125	22	31	40	300	167	180	280
150	40	45	49	350	245	340	395

Seat body FKM/natural rubber				fluid $_2\text{O} - 20^\circ\text{C}$			
working pressure BAR							
DN	0	6	DN	0	6	DN	0
80	7	11	200	62	78	400	515
100	11	16	250	120	134	450	578
125	29	42	300	225	241	500	607
150	52	65	350	465	495	600	1795

KI Series - Torque values - Nm - safety factor excluded

Seat body NBR/EPDM				fluid $_2\text{O} - 20^\circ\text{C}$			
working pressure BAR							
DN	0	6	10	16	DN	0	6
40	11	11	13	14	150	55	60
50	11	12	13	15	200	100	107
65	11	16	16	18	250	160	175
80	20	30	36	40	300	260	270
100	40	43	45	48	350	410	450
125	48	52	52	70	400	450	480

Seat body FKM/natural rubber				fluid $_2\text{O} - 20^\circ\text{C}$			
working pressure BAR							
DN	0	6	10	16	DN	0	6
40	14	14	16	17	150	66	72
50	14	15	16	18	200	120	129
65	14	20	20	22	250	192	210
80	24	36	44	48	300	312	330
100	48	52	54	58	350	498	545
125	60	62	64	84	400	550	584

KAKX Series - Torque values - Nm - safety factor excluded

Seat body NBR/EPDM				fluid $_2\text{O} - 20^\circ\text{C}$			
working pressure BAR							
DN	0	6	10	16	20	25	DN
40	12	12	14	15	15	-	300
50	12	13	14	16	17	20	350
65	12	17	17	19	20	31	400
80	21	32	38	42	44	49	450
100	42	45	47	50	53	65	500
125	50	55	55	74	77	82	600
150	58	63	88	95	99	103	700
200	105	112	189	221	231	320	800
250	175	190	231	336	352	440	



Head losses

NOTES: values indicated in this page is only for information

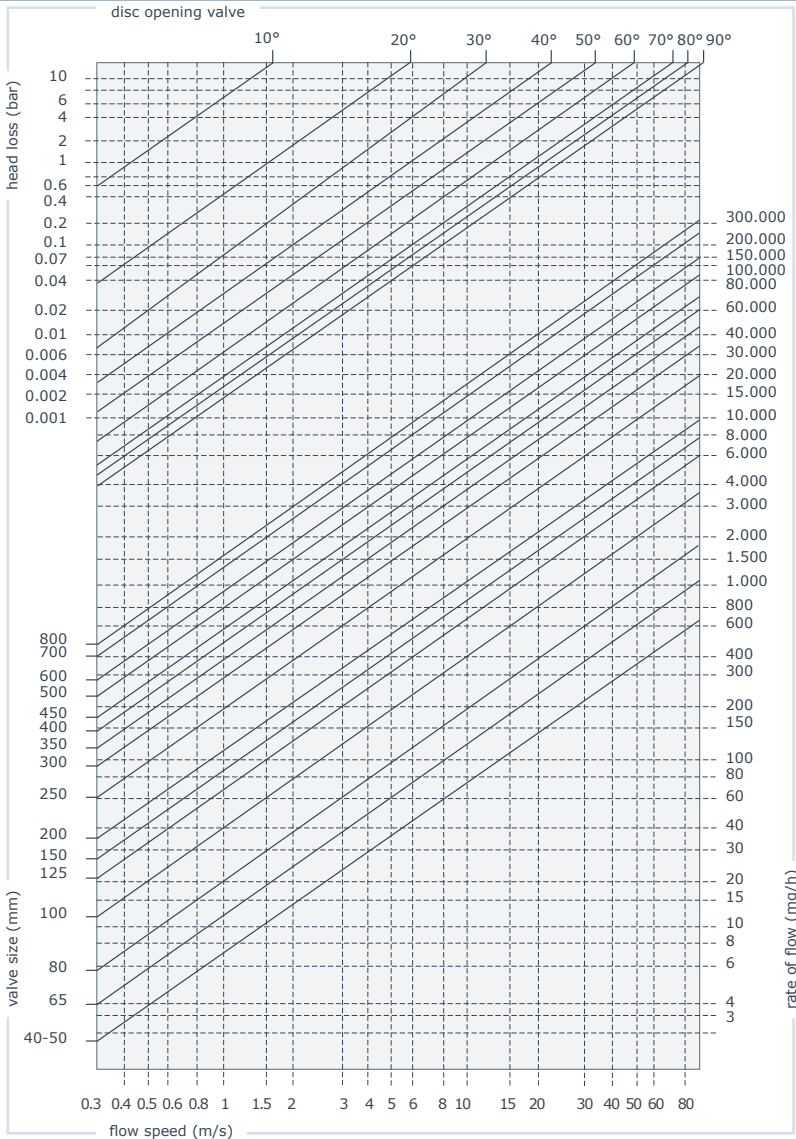

Formulae for calculation of rate flo

Liquids:
$$Q = \frac{KV}{\sqrt{\frac{PS}{\Delta P}}}$$

Q rate of flow (m³/h)
PS specific gravity (water=1)
ΔP pressure drop (bar)

Gas:
$$Q = 28.5 \frac{KV}{\sqrt{\frac{PS}{P_2 \cdot \Delta P}}}$$

Q rate of flow (m³/h)
PS specific gravity (air=1)
ΔP pressure drop (bar) (less than 1/2 inlet pressure)
P₂ outlet pressure

Steam:
$$Q = 22.5 \cdot KV \cdot \sqrt{P_2 \cdot \Delta P}$$

Q rate of flow (Kg/h)
ΔP pressure drop (bar) (less than 1/2 inlet pressure)
P₂ outlet pressure

Calculation of the rate of flow equivalent to H2

$$Q_e = Q \sqrt{\frac{d}{1000}}$$

For different liquid, gas or steam head losses are determined by equivalent water of flow, as follows:

Q_e equivalent water flow (mc/l o l/s)
Q fluid flow (mc/l o l/s)
d fluid specific gravity (Kg/mc)

Values KV (CV = 1,16 KV)

angle	40/50	65	80	100	125	150	200	250	300	350	400	450	500	600	700	800
5°	-	-	-	-	-	-	-	-	-	53	68	85	106	151	206	270
10°	-	-	-	-	-	-	-	21	49	123	161	199	246	354	482	629
15°	0,2	0,6	1,8	2,4	4,2	5,6	14	80	188	228	299	369	457	658	900	1168
20°	0,9	2,5	5,2	9,5	15	23	110	156	280	315	412	511	630	907	1234	2010
25°	3	6,1	12	22	38	61	125	225	354	457	597	740	914	1314	1789	2735
30°	6,1	11	21	39	69	112	211	310	381	661	863	1069	1320	1899	2585	5080
35°	9,9	18	33	60	105	166	303	433	521	890	1162	1440	1778	2560	3484	6254
40°	15	27	49	88	148	228	405	591	742	1184	1547	1916	2366	3407	4638	9700
45°	21	38	68	121	199	303	528	774	987	1552	2028	2512	3102	4466	6079	11581
50°	29	51	91	159	262	394	679	988	1252	2008	2620	3248	4010	5774	7860	15000
55°	39	68	119	207	338	505	863	1247	1571	2548	3318	4123	5090	7329	9976	17765
60°	53	90	156	269	434	641	1085	1591	2059	3225	4202	5218	6442	9277	12627	22200
65°	72	121	209	357	565	820	1364	2065	2807	3983	5196	6445	7957	11457	15595	26077
70°	92	161	283	487	768	1097	1788	2715	3744	5195	6775	8412	10377	14944	20341	34500
75°	109	209	381	662	1059	1507	2425	3625	4935	6964	9084	11269	13912	20032	27267	39546
80°	115	240	457	815	1303	1861	3043	4768	6831	9301	12142	15048	18578	26752	36413	47560
85°	115	253	502	906	1457	2008	3642	4890	8230	10280	13408	16632	20533	29568	40246	52566
90°	116	257	508	925	1492	2168	3838	5010	9233	10792	14082	17840	22024	31715	43166	56381



Flanges to be used



EN1092-1
Tipo 11
UNI
2280/81
2282/67

DIN
2631
2632
2633

A150
B16.5
welding neck



EN1092-1
Tipo 01
UNI
2276/77
2278/67

DIN
2575
2576
2577

A150
B16.5
slip on



EN1092-1
Tipo 02/32
UNI
6088/89
6090

DIN
2641
2642
2643



EN1092-1
Tipo 04/34
UNI
2289/90
2291

DIN
2672
2673
2674



EN1092-1
Tipo 02/33



NOTE
only valves
with vulcanized
seat (KA/KX)
are recommended
with these flanges

Compatibility flanges - body Wafer

DN	EN 1092-1 / EN 1092-2					ASME/ANSI			BS 10		JIS B2220		
	PN 6	PN 10	PN 16	PN 25	PN 40	class 125	class 150	class 300	tab D	tab E	5K	10K	16K
40	☐	✓	✓	✓	✓	✓	✓	●	✓	✓	✓	✓	✓
50	☐	✓	✓	✓	✓	✓	✓	✗	●	●	●	☐	✗
65	☐	✓	✓	✓	✓	✓	✓	●	●	●	✓	✓	☐
80	☐	✓	✓	✓	✓	✓	✓	●	●	●	●	●	✓
100	☐	✓	✓	●	●	✓	✓	✗	●	✓	✗	●	✓
125	☐	✓	✓	●(1)	●(1)	✓	✓	✗	✓	✓	☐	✓	●(1)
150	☐	✓	✓	●(1)	●(1)	✓	✓	✗	●	●	☐	✓	✗
200	☐	✓	✓	✓(2)	✗	✓	✓	✗	✓	✓	●	●	✓(2)
250	☐	✓	✓	●	✗	✓	✓	✗	✗	✓	●	✓	✗
300	☐	✓	✓	✓(2)	✗	✓	✓	✗	✓	✓	●	●	✓(2)
350	☐	✓	✓	●	✗	✓	✓	✗	✓	✓	●	●	●
400	☐	✓	✓	●	✗	✓	✓	✗	✗	✗	●	●	✓
450	☐	✓	✓	●	✗	✓	✓	✗	✗	●	●	✓	✗
500	☐	✓	✓	●	✗	✓	✓	✗	✗	✗	●	✓	✓
600	☐	✓	✓	●	✗	✓	✓	✗	✗	✗	●	✗	✗
700	☐	✓	✓	✗	✗		✓	✗			●	✓	✗
800	☐	✓	✓	✗	✗		✓	✗			●	✓	✗

✓ standard
● on request

☐ only body PN 6 version
✗ not possible

(1) only with ductile iron bodies
(2) standard with ductile iron and steel bodies,
on request with different materials

Compatibility flanges - body Lug

DN	EN 1092-1 / EN 1092-2					ASME/ANSI			BS 10		JIS B2220		
	PN 6	PN 10	PN 16	PN 25	PN 40	class 125	class 150	class 300	tab D	tab E	5K	10K	16K
40	☐	✓	✓	✓	✓	✓	✓	●	☐	☐	●	●	●
50	☐	✓	✓	✓	✓	✓	✓	✗	●	●	●	●	✗
65	☐	✓	✓	✓	✓	✓	✓	●	●	●	●	●	✓
80	☐	✓	✓	✓	✓	✓	✓	●	●	●	●	●	●
100	☐	✓	✓	●	●	✓	✓	✗	●	✓	✗	●	●
125	☐	✓	✓	●(1)	●(1)	✓	✓	✗	✓	✓(PN6)	✓	●	●(1)
150	☐	✓	✓	●(1)	●(1)	✓	✓	✗	●	●	●	✓	✗
200	☐	✓	✓	●	✗	✓	✓	✗	●	●	●	●	✗
250	☐	✓	✓	✗	✗	✓	✓	✗	✗	●	●	●	✗
300	☐	✓	✓	✗	✗	✓	✓	✗	●	●	●	✓(1)	✗
350	☐	✓	✓	✗	✗	✓	✓	✗	●	●	●	●	✗
400	☐	✓	✓	✗	✗	✓	✓	✗	●	●	●	●	●
450	☐	✓	✓	✗	✗	✓	✓	✗	✗	●	●	✓	✗
500	☐	✓	✓	✗	✗	✓	✓	✗	✗	✗	●	✓	✗
600	☐	✓	✓	●	✗	✓	✓	✗	✗	✗	●	✗	✗
700	☐	✓	✓	✗	✗		✓	✗			●	✓	✗
800	☐	✓	✓	✗	✗		✓	✗			●	✓	✗

✓ standard
● on request

☐ only body PN 6 version
✗ not possible

(1) only with ductile iron bodies
(2) standard with ductile iron and steel bodies,
on request with different materials



Bolts and rods dimensions

DN	Wafer valves											
	PN 6			PN 10			PN 16			ANSI 150		
	Bolts	Rods	N°	Bolts	Rods	N°	Bolts	Rods	N°	Bolts	Rods	N°
40	M12x80	M12x90	4	M16x90	M16x100	4	M16x90	M16x100	4	M14x90	M14x110	4
50	M12x90	M12x100	4	M16x100	M16x120	4	M16x100	M16x120	4	M16x100	M16x130	4
65	M12x100	M12x110	4	M16x110	M16x130	8	M16x110	M16x130	8	M16x110	M16x140	4
80	M16x100	M16x120	4	M16x110	M16x130	8	M16x110	M16x130	8	M16x120	M16x150	4
100	M16x110	M16x120	4	M16x120	M16x140	8	M16x120	M16x140	8	M16x120	M16x150	8
125	M16x120	M16x140	8	M16x120	M16x150	8	M16x120	M16x150	8	M20x130	M20x160	8
150	M16x120	M16x140	8	M20x130	M20x160	8	M20x130	M20x160	8	M20x140	M20x160	8
200	M16x130	M16x150	8	M20x140	M20x170	8	M20x140	M20x170	12	M20x150	M20x170	8
250	M16x140	M16x160	12	M20x150	M20x180	12	M24x150	M24x180	12	M22x160	M22x190	12
300	M20x150	M20x180	12	M20x160	M20x190	12	M24x160	M24x190	12	M22x170	M22x210	12
350	M20x150	M20x180	12	M20x160	M20x190	16	M24x170	M24x200	16	M24x180	M24x220	12
400	M20x180	M20x210	16	M24x190	M24x220	16	M27x210	M27x240	16	M27x210	M27x250	16
450	M20x190	M20x220	16	M24x200	M24x230	20	M27x220	M27x250	20	M27x230	M27x270	16
500	M20x210	M20x240	20	M24x210	M24x240	20	M30x240	M30x280	20	M27x250	M27x290	20
600	M24x240	M24x270	20	M27x250	M27x290	20	M33x270	M33x320	20	M33x290	M33x340	20
700	M24x250	M24x280	24	M27x260	M27x310	24	M33x280	M33x330	24	M33x350	M33x400	28
800	M27x280	M27x320	24	M30x290	M30x350	24	M36x320	M36x360	24	M39x400	M33x460	28

DN	Lug valves							
	PN 6		PN 10		PN 16		ANSI 150	
	Bolts	N°	Bolts	N°	Bolts	N°	Bolts	N°
40	M12x30	8	M16x30	8	M16x30	8	M14x30	8
50	M12x35	8	M16x35	8	M16x35	8	M16x35	8
65	M12x35	8	M16x40	16	M16x40	16	M16x40	8
80	M16x40	8	M16x40	16	M16x40	16	M16x40	8
100	M16x40	8	M16x40	16	M16x40	16	M16x45	16
125	M16x45	16	M16x45	16	M16x45	16	M20x50	16
150	M16x45	16	M20x45	16	M20x45	16	M20x50	16
200	M16x50	16	M20x50	16	M20x50	24	M20x55	16
250	M16x55	24	M20x55	24	M24x55	24	M22x60	24
300	M20x60	24	M20x60	24	M24x60	24	M22x60	24
350	M20x60	24	M20x60	32	M24x65	32	M24x65	24
400	M20x70	32	M24x70	32	M27x70	32	M27x80	32
450	M20x80	32	M24x80	40	M27x80	40	M27x80	32
500	M20x80	40	M24x80	40	M30x80	40	M27x90	40
600	M24x90	40	M27x90	40	M33x100	40	M33x100	40
700	M24x100	48	M27x100	48	M33x110	48	M33x130	56
800	M27x110	48	M30x120	48	M36x130	48	M39x150	56

NOTE 1 Screw and rod dimensions have been calculated with WELDING NECK flanges PN 6/10/16 (EN1092-1 Type 11) ANSI150 (ANSI B16.5)

NOTE 2 Number of nuts should be double when WAFER valves are assembled with threaded rods.

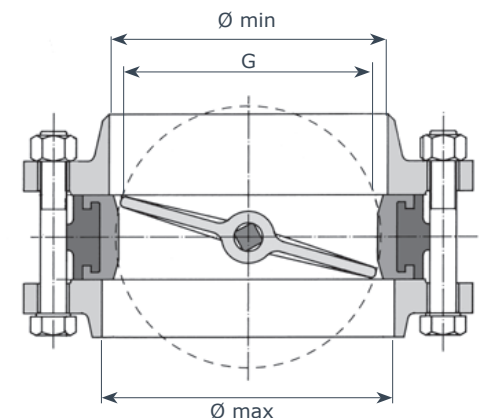

DN	40	50	65	80	100	125	150	200	250	300	350	400	450	500	600	700	800
G	36	35	50	67	87	113	140	191	241	289	332	376	430	475	575	670	757
Ø min	46	44	60	75	98	122	148	196	244	296	342	378	440	485	585	681	782
Ø max	49	62	80	93	118	146	175	225	275	330	372	422	450	500	600	717	815



Installation

Assembly

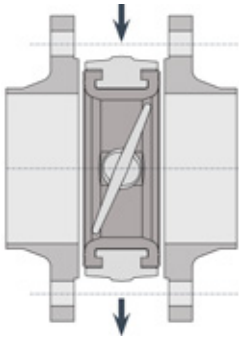

1 - Leave a space between flanges so that valve can be easily inserted and removed.

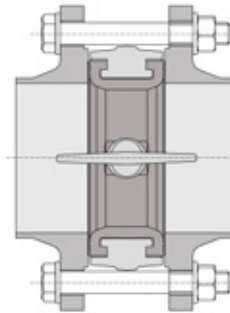

2 - Open completely the valve before tightening flanges.

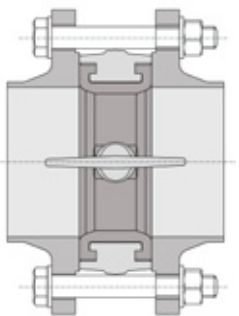

3 - Tighten bolts till flanges are in contact with valve body.

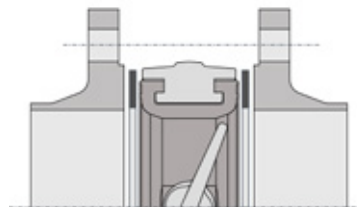

4 - **NOTE:** do not insert other packing between flange and valve.

NOTE: Weld the pipe only in spots with the valve between flanges. Remove the valve before finishing welding to avoid that heat damage the seat. Clean carefully the welding to avoid that slags damage the seat.

Installation for powders and muddy fluid

In case of use with powders or muddy fluids, install the valve with horizontal rotation axis, to allow sediments to flow easily on opening.

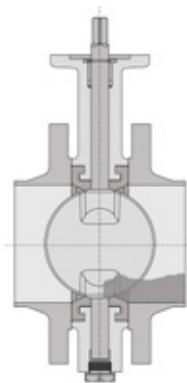

Wrong
Vertical rotation axis

←
powders or muddy fluids

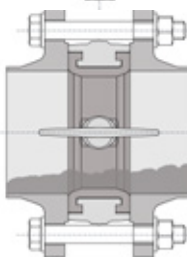

Right
Horizontal rotation axis

←
powders or muddy fluids

This type of installation is always advisable with valve diameters over DN 400.

End piping installation

When valves are installed end of piping, a counterflange as per dwg type B is needed to secure tightness at max pressure.

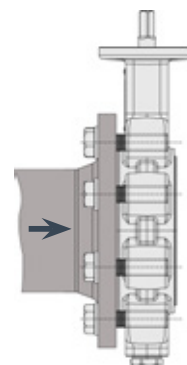

Type A installation without counterflange

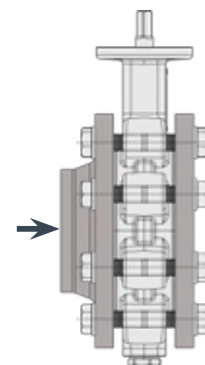

Type B installation with counterflange

valve type	P _{max} (Bar)	
	type A inst.	type B inst.
BLPD	4	6
BLKI	6	16
BLKA	16	20
BLKX	16	25