

# → Series 6450

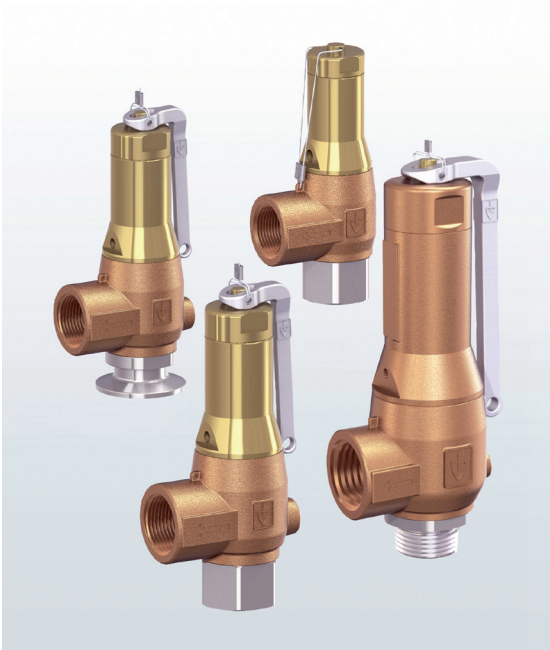

### ■ SUITABLE FOR

Liquids	neutral and non-neutral	
Air, gases and vapours	neutral and non-neutral	
Steam		

### ■ EXAMPLES OF USE

For the protection of:

- Pressure-vessels/-systems for neutral / non-neutral vapours, gases and liquids
- Steam boilers and steam plants

taking into account the plant-specific regulations and making use of the suitable valve versions and sealing materials.

- Mechanical engineering
- pump protection
- Pressure booster systems water- / air-side
- cooling-/chilling-systems
- Steam- and industrial-boiler systems

**Safety valves are set and sealed at the factory.**

### ■ APPROVALS

TÜV Type test approval	D/G,F
EU type examination	S/G, L
ASME	S, G, L
CRN	S, G, L
KGS	G
<b>Type approval ACS</b>	
<b>Type approval WRAS</b>	
TR ZU 032/2013 - TR ZU 010/2011	D/G (S/G), F (L)
<b>Requirements</b>	
AD 2000 Data sheet A2	TRD 421
DIN EN ISO 4126-1	ASME-Code Sec. VIII Div. 1
PED 2014/68/EU	KGS AA 319
UK PESR 2016 No. 1105	
<b>Classification society</b>	
DNV	DNV
American Bureau of Shipping	ABS
Russian Maritime Register of Shipping	RS
Registro Italiano Navale	RINA



### ■ MATERIAL



### ■ SPECIFICATION



1/2" – 2"



– 50°C to + 205°C  
depending on version



0,5 – 16 bar

### ■ MATERIALS

Component	Material	DIN EN	ASME
Inlet body	Stainless steel	1.4404	316 L
Outlet body	Gunmetal	CC499K	CC499K
Internal parts	Brass	CW617N	CW617N
Internal wetted parts	Stainless steel	1.4404	316 L
Spring	Stainless steel	1.4310 / 1.4568	302 / 631

<b>m</b>	Standard with diaphragm	The diaphragm prevents the medium entering into the spring housing and protects moving parts from being affected by the medium.
----------	-------------------------	---

## ■ MEDIUM

<b>GF</b>	gaseous and liquid	Air, vapours, gases, liquids and - depending on seal - also for steam
-----------	--------------------	---

## ■ TYPE OF LIFTING MECHANISM

<b>L</b>	Lifting lever
<b>0</b>	without lifting device

## ■ AVAILABLE NOMINAL DIAMETERS AND CONNECTION SIZES

Nominal diameter DN		15	20	25	32	40	50
<b>Inlet</b>		1/2" (15)	3/4" (20)	1" (25)	1 1/4" (32)	1 1/2" (40)	2" (50)
<b>Outlet</b>	3/4" (20)	■					
	1" (25)		■				
	1 1/4" (32)			■			
	1 1/2" (40)				■		
	2" (50)					■	
	2 1/2" (65)						■

## ■ TYPE OF CONNECTION INLET / OUTLET

<b>f / f</b>	Standard	Female thread BSP-P / Female thread BSP-P	DIN EN ISO 228-1 / DIN EN ISO 228-1
<b>m / f</b>		Male thread BSP-P / Female thread BSP-P	DIN EN ISO 228-1 / DIN EN ISO 228-1
<b>NPT-f / NPT-f</b>		Female thread NPT-f / Female thread NPT-f	ANSI B1.20.1 / ANSI B1.20.1
<b>NPT-m / NPT-f</b>		Male thread NPT-m / Female thread NPT-f	ANSI B1.20.1 / ANSI B1.20.1
<b>KLSISO/f</b>	Clamp connection / Female thread BSP-P		DIN 32676-B / DIN EN ISO 228-1 Pipe Standard DIN EN ISO 1127

Other connection types possible on request

## ■ SEAT SEALS / DIAPHRAGMS

<b>PTFE / EPDM</b>	Polytetrafluorethylen / Ethylen-Propylene-Diene (Standard)	Flat seal and moulded diaphragm	-50°C to +205°C
<b>EPDM / EPDM</b>	Ethylen-Propylene-Diene / Ethylen-Propylene-Diene	Flat seal and moulded diaphragm	-50°C bis +150°C
<b>PTFE / FKM</b>	Polytetrafluorethylen / Fluorcarbon	Flat seal and moulded diaphragm	-30°C to +200°C
<b>FKM / FKM</b>	Fluorcarbon / Fluorcarbon	Flat seal and moulded diaphragm	-20°C to +200°C

■ NOMINAL DIAMETERS, CONNECTIONS, INSTALLATION DIMENSIONS

Series 6450: Connection, installation dimensions, ranges of adjustment							
Nominal diameter	DN	15	20	25	32	40	50
Connection DIN EN ISO 228	G	1/2" (15)	3/4" (20)	1" (25)	1 1/4" (32)	1 1/2" (40)	2" (50)
Outlet DIN EN ISO 228	G1	3/4" (20)	1" (25)	1 1/4" (32)	1 1/2" (40)	2" (50)	2 1/2" (65)
Installation dimensions in mm	L	35,5	45	48	58	68	80
	Lmax	63	77	102	145	150	155
	H	82	107	132	168	199	240
	H1	90	114	140	192	229	276
	h	35	45	47	55	65	75
	h1	35	46	53	59	72	82
	h2	34	44	51	57	65	76
	Hmax	102	132	160	220	260	310
	d1	18,1	23,7	29,7	38,4	44,3	56,3
	d2	43,5	43,5	43,5	56,5	56,5	70,5
	d3	50,5	50,5	50,5	64	64	77,5
	SW1	30	36	50	55	70	80
	SW2	30	38	50	55	70	80
	SW3	34	41	50	60	70	90
G2	-	1/4"	1/4"	1/4"	1/4"	1/4"	1/4"
do	13	18	23	30	39	48	
Coefficients of flow ISO 4126-1	$\alpha_w / K_{dr} (F)$	0,45	0,43	0,43	0,38	0,38	0,38
	$\alpha_w / K_{dr} (D/G)^1)$	0,64	0,63	0,63	0,55	0,55	0,55
Coefficients of flow ASME-Code Sec. VIII Div. 1	$\alpha_w / K_{dr} (F)$	0,43	0,43	0,43	0,36	0,36	0,36
	$\alpha_w / K_{dr} (D/G)$	0,65	0,65	0,65	0,55	0,55	0,55
Weight	kg	0,6	1,1	1,9	3,4	6	8,9
Range of adjustment	bar	0,5 - 16	0,5 - 16	0,5 - 16	0,5 - 16	0,5 - 16	0,5 - 16
Range of adjustment ASME	psi	15 - 232	15 - 232	15 - 232	15 - 232	15 - 232	15 - 232

<sup>1</sup>Flow coefficients for blow-off pressures < 3,0 bar: Please refer to the Flow Coefficients Chart.

■ MAIN DIMENSIONS, INSTALLATION DIMENSIONS

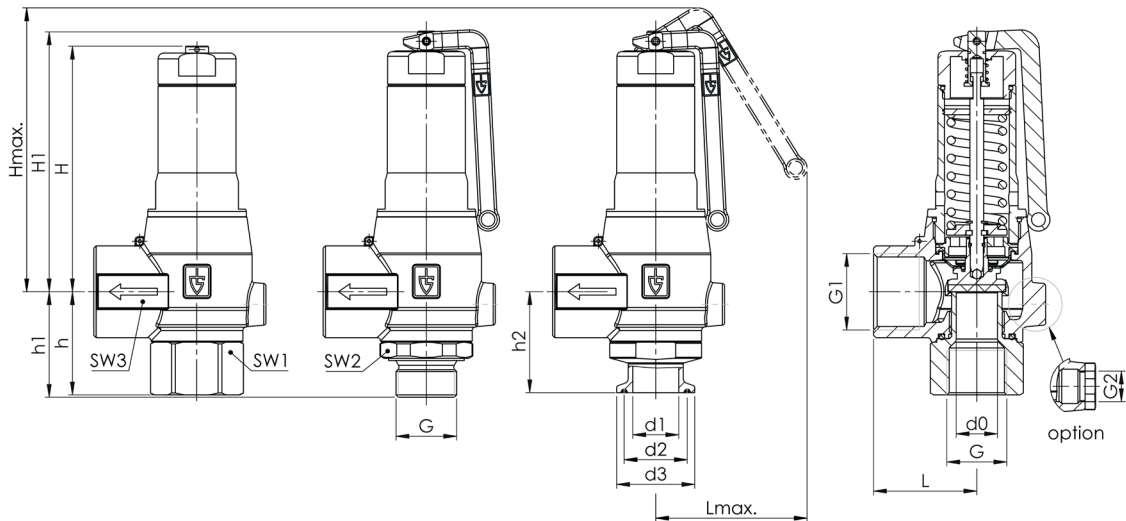

Series 6450 ■ INDIVIDUAL SELECTION / VALVE CONFIGURATION

Series	Valve version	Medium	Lifting device	Nominal diameter DN	Connection type		Connection size		Seal	Options	Set pressure	Quantity
					Inlet	Outlet	Inlet	Outlet				
6450	m	GF	L	15	f	f	15	15	PTFE/EPDM		6	2
6450	m	GF	O	25	m	f	25	25	FKM/FKM		2	4
6450	m	GF				f						
6450	m	GF				f						

■ TECHNICAL FINISHES, VARIANTS, ACCESSORIES

A02	Connection for condensate in the outlet body	<input type="checkbox"/>
		<input type="checkbox"/>
		<input type="checkbox"/>

■ PROPERTIES

P01	Oil- and grease-free production	<input type="checkbox"/>	P03	Galvanically nickel-plated finish	<input type="checkbox"/>
P02	Chemically nickel-plated finish	<input type="checkbox"/>	P04	Chrome-plated finish	<input type="checkbox"/>
		<input type="checkbox"/>			<input type="checkbox"/>

■ CERTIFICATES / APPROVALS

C01	Factory certificate acc. DIN EN 10204 2.2 (WKZ 2.2)	<input type="checkbox"/>	C06	ATEX evaluation acc. to 2014/34/EU	<input type="checkbox"/>
C02	Test certificate acc. DIN EN 10204 3.1 (WPZ 3.1)	<input type="checkbox"/>	C07	SIL evaluation relating to IEC 61508-2	<input type="checkbox"/>
C03	Material test certificate acc. DIN EN 10204 3.1 (MPZ 3.1) (pressure retaining part)	<input type="checkbox"/>	C09	Seat tightness test with helium, leak detection method under vacuum incl. Factory Inspection Certificate 3.1 acc. to DIN EN 10204	<input type="checkbox"/>
C04	TÜV/DEKRA individual inspection acc. EN 10204 3.2 (TÜV/DEKRA-APZ)	<input type="checkbox"/>	C10	Certificate of oil- and grease free production	<input type="checkbox"/>
C05	Sealing material Manufacturer certification (FDA, USP 3, 3-A,...), Please indicate description of certificate: _____	<input type="checkbox"/>			<input type="checkbox"/>

■ ADMISSIONS / ACCREDITATIONS

AA1	EC Type examination acc. to Directive 2014/68/EU	<input type="checkbox"/>	AK1	Det Norske Veritas (DNV) type approval	<input type="checkbox"/>
AA2	TÜV component test acc. to VdTÜV specification sheet SV 100	<input type="checkbox"/>	AK3	American Bureau of Shipping (ABS) type approval	<input type="checkbox"/>
AA3	Certification acc. to ASME Boiler and Pressure Vessel Code, Section VIII.Div 1 (ASME)	<input type="checkbox"/>	AK5	Russian Maritime Register of Shipping (RMRS) type approval	<input type="checkbox"/>
AA4	EAC - certificate/declaration with passport for the valve and laser marking of the valve	<input type="checkbox"/>	AK6	Registro Italiano Navale (RINA) type approval	<input type="checkbox"/>
AA6	Certification acc. to Korean Gas Safety Corporation (KGS)	<input type="checkbox"/>	AL	Individual inspection by notified body inspector – (body to be indicated): _____	<input type="checkbox"/>
AA7	Registration according to Canadian Registration Number (CRN)	<input type="checkbox"/>			<input type="checkbox"/>
AA11	UK Type examination acc. to Directive UK PESR 2016 No. 1105	<input type="checkbox"/>			<input type="checkbox"/>
AB2	Water regulations and advisory scheme WRAS type approval	<input type="checkbox"/>			<input type="checkbox"/>

■ ENQUIRY

Series 6450: Blowing-off rates at 10% above set pressure										
Nominal diameter DN		15			20			25		
		d0 = 13 mm			d0 = 18 mm			d0 = 23 mm		
Set pressure bar		I	II	III	I	II	III	I	II	III
Air I Nm <sup>3</sup> /h	0,5	76	62	2,3	143	117	4,3	234	191	7,0
	1	110	88	3,2	207	165	5,8	338	269	9,5
	2	180	142	4,5	340	268	8,2	556	437	13,5
Steam II kg/h	3	248	193	5,5	468	365	10,1	764	595	16,5
	4	312	242	6,4	592	458	11,7	966	748	19,1
	5	376	290	7,1	712	549	13,1	1163	896	21,3
Water III m <sup>3</sup> /h	6	440	337	7,8	833	639	14,3	1359	1043	23,4
	7	503	385	8,4	953	729	15,5	1556	1190	25,2
	8	567	432	9,0	1074	819	16,5	1753	1337	27,0
	9	631	480	9,6	1194	908	17,5	1950	1483	28,6
	10	694	527	10,1	1315	998	18,5	2147	1629	30,2
	11	758	574	10,6	1435	1088	19,4	2343	1776	31,7
	12	822	622	11,1	1556	1177	20,2	2540	1922	33,1
	13	885	669	11,5	1676	1266	21,1	2737	2068	34,4
	14	949	716	11,9	1797	1356	21,9	2934	2214	35,7
	15	1013	764	12,4	1917	1446	22,6	3130	2361	37,0
	16	1076	811	12,8	2038	1535	23,4	3327	2507	38,2

Series 6450: Blowing-off rates at 10% above set pressure										
Nominal diameter DN		32			40			50		
		d0 = 30 mm			d0 = 39 mm			d0 = 48 mm		
Set pressure bar		I	II	III	I	II	III	I	II	III
Air I Nm <sup>3</sup> /h	0,5	338	276	10,5	571	466	17,7	864	706	26,8
	1	491	392	14,3	831	662	24,1	1258	1003	36,5
	2	816	642	20,2	1379	1085	34,2	2089	1643	51,8
Steam II kg/h	3	1128	879	24,8	1907	1486	41,9	2888	2251	63,5
	4	1430	1107	28,7	2417	1872	48,4	3661	2835	73,4
	5	1721	1326	32,1	2909	2241	54,2	4407	3395	82,1
Water III m <sup>3</sup> /h	6	2013	1544	35,1	3402	2609	59,4	5153	3953	89,9
	7	2304	1762	37,9	3894	2977	64,1	5899	4510	97,1
	8	2595	1979	40,6	4386	3344	68,6	6644	5066	103,9
	9	2887	2196	43,0	4879	3711	72,7	7390	5621	110,2
	10	3178	2412	45,4	5371	4077	76,7	8136	6175	116,1
	11	3469	2629	47,6	5863	4443	80,4	8882	6730	121,8
	12	3761	2845	49,7	6356	4809	84,0	9627	7284	127,2
	13	4052	3061	51,7	6848	5174	87,4	10373	7837	132,4
	14	4343	3278	53,7	7340	5541	90,7	11119	8393	137,4
	15	4635	3495	55,6	7833	5907	93,9	11865	8948	142,3
	16	4926	3711	57,4	8325	6272	97,0	12611	9501	146,9

Series 6450: Blowing-off rates at 10% above set pressure											
Nominal diameter DN		15			20			25			
		d0 = 13,0 mm (0,5118 in)			d0 = 18,0 mm (0,7087 in)			d0 = 23,0 mm (0,9055 in)			
Set pressure bar (g)		Air	Steam	Water	Air	Steam	Water	Air	Steam	Water	
psi (g)		I	II	III	I	II	III	I	II	III	
SCFM		PPH	GPM	SCFM	PPH	GPM	SCFM	PPH	GPM		
Air I	15	80,2	225,2	14,2	153,8	431,8	27,2	251,1	704,9	44,5	
	Nm³/h	30	117,0	328,5	19,2	224,3	629,8	36,9	366,2	1028,3	60,2
		40	144,0	404,3	22,2	276,0	775,0	42,6	450,7	1265,4	69,5
Steam II	50	171,0	480,0	24,8	327,8	920,3	47,6	535,2	1502,6	77,8	
	kg/h	60	197,9	555,8	27,2	379,5	1065,5	52,2	619,6	1739,7	85,2
		70	224,9	631,5	29,4	431,2	1210,8	56,3	704,1	1976,8	92,0
Water III	80	251,9	707,3	31,4	483,0	1356,0	60,2	788,5	2214,0	98,3	
	m³/h	90	278,9	783,1	33,3	534,7	1501,2	63,9	873,0	2451,1	104,3
		100	305,9	858,8	35,1	586,4	1646,5	67,3	957,4	2688,2	110,0
		110	332,9	934,6	36,8	638,1	1791,7	70,6	1041,9	2925,4	115,3
		120	359,8	1010,3	38,5	689,9	1936,9	73,8	1126,4	3162,5	120,5
		130	386,8	1086,1	40,1	741,6	2082,2	76,8	1210,8	3399,6	125,4
		140	413,8	1161,8	41,6	793,3	2227,4	79,7	1295,3	3636,8	130,1
		150	440,8	1237,6	43,0	845,0	2372,7	82,5	1379,7	3873,9	134,7
		160	467,8	1313,3	44,4	896,8	2517,9	85,2	1464,2	4111,0	139,1
		170	494,7	1389,1	45,8	948,5	2663,1	87,8	1548,6	4348,2	143,4
		180	521,7	1464,9	47,1	1000,2	2808,4	90,4	1633,1	4585,3	147,5
		190	548,7	1540,6	48,4	1052,0	2953,6	92,8	1717,5	4822,4	151,6
		200	575,7	1616,4	49,7	1103,7	3098,9	95,2	1802,0	5059,5	155,5
		210	602,7	1692,1	50,9	1155,4	3244,1	97,6	1886,5	5296,7	159,3
		220	629,7	1767,9	52,1	1207,1	3389,3	99,9	1970,9	5533,8	163,1
	230	656,6	1843,6	53,3	1258,9	3534,6	102,1	2055,4	5770,9	166,8	
	232	662,0	1858,8	53,5	1269,2	3563,6	102,6	2072,3	5818,4	167,5	

Series 6450: Blowing-off rates at 10% above set pressure											
Nominal diameter DN		32			40			50			
		d0 = 30,0 mm (1,1811 in)			d0 = 39,0 mm (1,5354 in)			d0 = 48,0 mm (1,8898 in)			
Set pressure bar (g)		Air	Steam	Water	Air	Steam	Water	Air	Steam	Water	
psi (g)		I	II	III	I	II	III	I	II	III	
SCFM		PPH	GPM	SCFM	PPH	GPM	SCFM	PPH	GPM		
Air I	15	358,8	1007,4	63,3	606,4	1702,5	107,0	918,5	2579,0	162,1	
	Nm³/h	30	523,4	1469,5	85,7	884,5	2483,5	144,9	1339,9	3762,0	219,5
		40	644,1	1808,4	99,0	1088,5	3056,3	167,3	1648,9	4629,6	253,5
Steam II	50	764,8	2147,3	110,7	1292,5	3629,0	187,1	1957,9	5497,1	283,4	
	kg/h	60	885,5	2486,2	121,3	1496,5	4201,7	204,9	2266,9	6364,7	310,4
		70	1006,2	2825,1	131,0	1700,5	4774,4	221,4	2575,8	7232,3	335,3
Water III	80	1126,9	3164,0	140,0	1904,4	5347,1	236,6	2884,8	8099,8	358,5	
	m³/h	90	1247,6	3502,9	148,5	2108,4	5919,9	251,0	3193,8	8967,4	380,2
		100	1368,3	3841,8	156,5	2312,4	6492,6	264,6	3502,8	9834,9	400,8
		110	1489,0	4180,7	164,2	2516,4	7065,3	277,5	3811,8	10702,5	420,3
		120	1609,7	4519,5	171,5	2720,4	7638,0	289,8	4120,8	11570,0	439,0
		130	1730,4	4858,4	178,5	2924,3	8210,8	301,7	4429,8	12437,6	456,9
		140	1851,1	5197,3	185,2	3128,3	8783,5	313,0	4738,8	13305,2	474,2
		150	1971,8	5536,2	191,7	3332,3	9356,2	324,0	5047,7	14172,7	490,8
		160	2092,5	5875,1	198,0	3536,3	9928,9	334,7	5356,7	15040,3	506,9
		170	2213,2	6214,0	204,1	3740,3	10501,6	345,0	5665,7	15907,8	522,5
		180	2333,9	6552,9	210,0	3944,2	11074,4	355,0	5974,7	16775,4	537,7
		190	2454,6	6891,8	215,8	4148,2	11647,1	364,7	6283,7	17642,9	552,4
		200	2575,3	7230,7	221,4	4352,2	12219,8	374,2	6592,7	18510,5	566,8
		210	2696,0	7569,5	226,9	4556,2	12792,5	383,4	6901,7	19378,0	580,8
		220	2816,7	7908,4	232,2	4760,2	13365,3	392,4	7210,7	20245,6	594,4
	230	2937,4	8247,3	237,4	4964,1	13938,0	401,2	7519,7	21113,2	607,8	
	232	2961,5	8315,1	238,4	5004,9	14052,5	403,0	7581,4	21286,7	610,4	