

→ Series 684



■ SUITABLE FOR

Liquids	neutral and non-neutral	
Air, gases and vapours	neutral and non-neutral	

■ EXAMPLES OF USE

For the protection of:

- commercial and industrial plants against too high supply pressure.

Use of pressure reducing valves, when in a piping system inspite of varying pressures on the inlet side a specific pressure on the outlet side must be kept.

- Compressed air supply plants
- Pneumatic control units
- Pressure booster plants air-side
- Shipbuilding industry and offshore plants
- Industrial gas plant construction
- PET blow moulding machines
- Blasting plants



■ MATERIAL



■ SPECIFICATION



1/4" – 2"



– 40°C to + 120°C
depending on
version



Inlet pressure:
up to 60 bar
Outlet pressure:
0,5 to 50 bar
depending on version

■ APPROVALS

European Pressure Equipment Directive

TR ZU 032/2013 - TR ZU 010/2011

Requirements

PED 2014/68/EU
UK PESR 2016 No. 1105

Classification society

DNV	DNV
Lloyd's Register EMEA	LR EMEA
Bureau Veritas	BV
Russian Maritime Register of Shipping	RS
Registro Italiano Navale	RINA

■ MATERIALS

Component	Material	DIN EN	ASME
Inlet body	Gunmetal	CC499K	CC499K
Outlet body	Gunmetal	CC499K	CC499K
Internal parts	Brass	CW617N	CW617N
Spring	Spring steel with anti-rust protection	1.1200	ASTM A228

Version 2023 / 06

m	with diaphragm	High-quality heat-resistant elastomere, fabric reinforced diaphragm. Adjustment by means of non-rising spindle. Balanced single seat valve, pressure gauge connection G1/4" on both sides of body. Please take note of the outlet pressure range.
k	with piston	Brass piston with seal and support ring. Adjustment by means of non-rising spindle. Balanced single seat valve, pressure gauge connection G1/4" on both sides of body. Please take note of the outlet pressure ranges.

■ MEDIUM

GS	gaseous with secondary venting	Compressed air and gases. Non-neutral, poisonous gases only in combination with ducted exhaust.
GFO	gaseous and liquid without secondary venting	for water and non-sticking liquids, compressed air and gases

■ OUTLET PRESSURE RANGES

SM	Standard version with diaphragm	Inlet pressure: up to 60 bar	Outlet pressure: 0,5 to 15 bar
SK	Standard version with piston	Inlet pressure: up to 60 bar	Outlet pressure: 5 to 30 bar
HK	High-pressure version with piston	Inlet pressure: up to 60 bar	Outlet pressure: 10 to 50 bar

■ AVAILABLE NOMINAL DIAMETERS AND CONNECTION SIZES

Nominal diameter DN	8	10	15	20	25	40	50
Inlet female connection	1/4" (8)	3/8" (10)	1/2" (15)	3/4" (20)	1" (25)	1 1/2" (40)	2" (50)
Outlet female connection	1/4" (8)	3/8" (10)	1/2" (15)	3/4" (20)	1" (25)	1 1/2" (40)	2" (50)

■ TYPE OF CONNECTION INLET / OUTLET THREADED CONNECTIONS

f / f	Standard	Female thread BSP-P / Female thread BSP-P	DIN EN ISO 228-1 / DIN EN ISO 228-1
--------------	----------	---	-------------------------------------

■ SEALS

FKM	Fluorocarbon	Elastomere moulded diaphragm and seals	-10°C to +120°C
EPDM	Ethylene propylene diene	Elastomere moulded diaphragm and seals	-40°C to +120°C

■ NOMINAL DIAMETERS, CONNECTIONS, INSTALLATION DIMENSIONS

Series 684: Connection, installation dimensions, ranges of adjustment								
Nominal diameter	DN	8	10	15	20	25	40	50
Connection DIN EN ISO 228	G	1/4" (8)	3/8" (10)	1/2" (15)	3/4" (20)	1" (25)	1 1/2" (40)	2" (50)
Inlet pressure up to	bar	60	60	60	60	60	60	60
Outlet pressure:	SM	0,5-15	0,5-15	0,5-15	0,5-15	0,5-15	0,5-15	0,5-15
	SK	5-30	5-30	5-30	5-30	5-30	5-30	5-30
	HK	10-50	10-50	10-50	10-50	10-50	10-50	10-50
Installation dimensions in mm	L	68	68	60	78	102	136	136
	H	120	120	120	180	215	260	270
	h	33	33	33	40	56	63	70
	SW	26	26	26	32	44	58	70
Ducted exhaust connection	D	1/8"	1/8"	1/8"	1/8"	1/8"	1/8"	1/8"
Dimensions of optional wall mount	L1	38	38	38	51	61	85	85
	H1 / H2	18 / 62	18 / 62	18 / 62	18 / 58	22 / 80	15	15
	B / B1	5,5	5,5	5,5	6,5	8,5	10,5 / 90	10,5 / 90
Weight	kg	1,2	1,2	1,2	2,8	5,3	9,4	10,2
Coefficient of flow K_{vs}	m ³ /h	1,6	1,6	1,6	3,4	5,5	12,7	12,7

The K_{vs} value was determined according to DIN EN 60534-2-3. Instructions on how to determine size and capacity are to be found under section 2.

■ MAIN DIMENSIONS, INSTALLATION DIMENSIONS

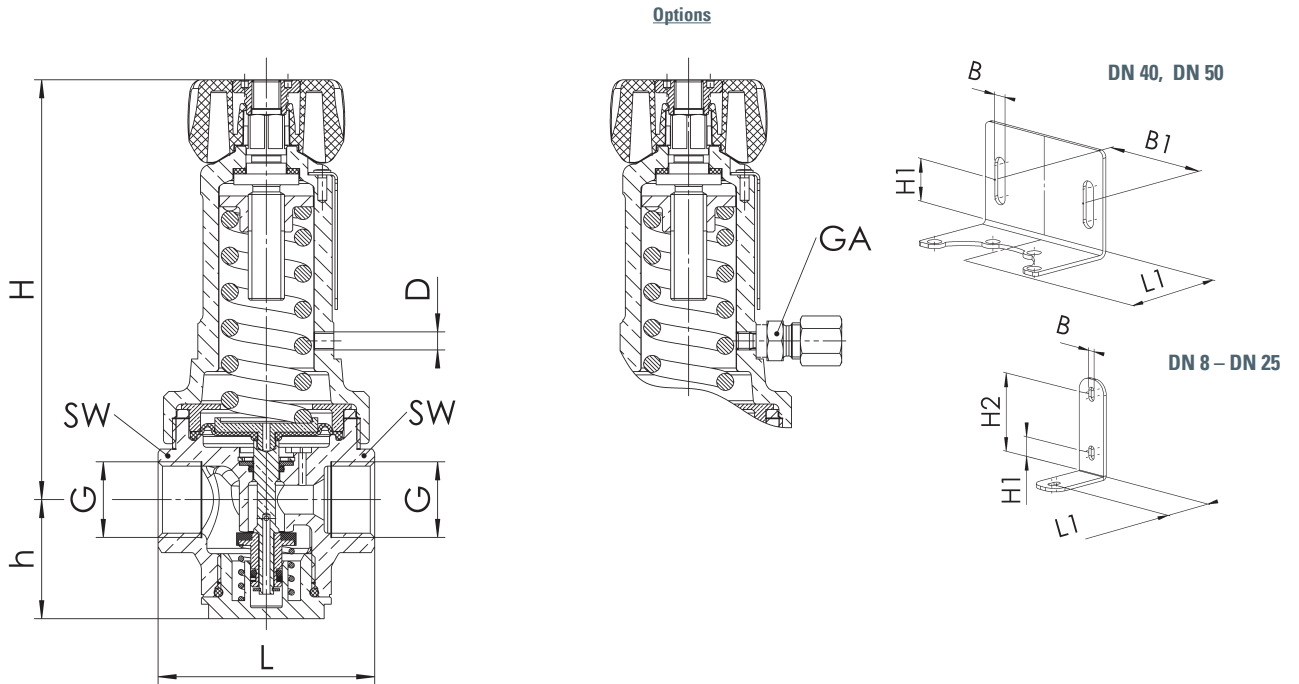

Series	Valve version	Medium	Outlet pressure	Nominal diameter DN	Connection type		Connection size		Seal	Options	Optional: fixed setting	Quantity
					Inlet	Outlet	Inlet	Outlet				
684	<i>m</i>	<i>GS</i>	<i>SM</i>	<i>20</i>	f	f	<i>20</i>	<i>20</i>		<i>FKM</i>	<i>S17</i>	<i>5</i>
684	<i>k</i>	<i>GFO</i>	<i>SK</i>	<i>40</i>	f	f	<i>40</i>	<i>40</i>		<i>EPDM</i>		<i>1</i>
684					f	f						
684					f	f						

■ PROPERTIES

S17	Supply with manometers suitable for the valve finish	<input type="checkbox"/>	<input type="checkbox"/>
S27	Without hand wheel, plastic cap. To be set by means of hexagon wrench	<input type="checkbox"/>	<input type="checkbox"/>
S68	Wall mount	<input type="checkbox"/>	<input type="checkbox"/>
S69	Inside coating for improving the dry run properties with strong solvents such as e.g. CO2	<input type="checkbox"/>	<input type="checkbox"/>

*Only valid for nominal width DN 8, DN 10, DN 15 and DN 25.

■ OPTIONS

GOX	Especially for gaseous O2 applications by employment of specific materials including oil- and grease free production process	<input type="checkbox"/>	P10	Ducted secondary venting of non-neutral gases in case of medium G	<input type="checkbox"/>
P01	Oil- and grease-free production	<input type="checkbox"/>	FE	Setting and sealing	<input type="checkbox"/>
P02	Chemically nickel-plated finish	<input type="checkbox"/>	S71	Preliminary setup for protection against manipulation of the preset pressure (seal)	<input type="checkbox"/>
P03	Galvanically nickel-plated finish	<input type="checkbox"/>			<input type="checkbox"/>

■ CERTIFICATES / APPROVALS

C01	Factory certificate acc. DIN EN 10204 2.2 (WKZ 2.2)	<input type="checkbox"/>	C05	Sealing material Manufacturer certification (FDA, USP 3, 3-A,...), Please indicate description of certificate:	<input type="checkbox"/>
C02	Test certificate acc. DIN EN 10204 3.1 (WPZ 3.1)	<input type="checkbox"/>	C06	ATEX evaluation acc. to 2014/34/EU	<input type="checkbox"/>
C03	Material test certificate acc. DIN EN 10204 3.1 (MPZ 3.1) (pressure retaining part)	<input type="checkbox"/>	C10	Certificate of oil- and grease free production	<input type="checkbox"/>
C04	TÜV/DEKRA individual inspection acc. EN 10204 3.2 (TÜV/DEKRA-APZ)	<input type="checkbox"/>			<input type="checkbox"/>

■ ADMISSIONS / ACCREDITATIONS

AA1	EC Type examination acc. to Directive 2014/68/EU	<input checked="" type="checkbox"/>	AK1	Det Norske Veritas (DNV) type approval	<input type="checkbox"/>
AA4	EAC - certificate/declaration with passport for the valve and laser marking of the valve	<input type="checkbox"/>	AK2	Lloyd's Register (LR) type approval	<input type="checkbox"/>
AA11	UK Type examination acc. to Directive UK PESR 2016 No. 1105	<input type="checkbox"/>	AK3	American Bureau of Shipping (ABS) type approval	<input type="checkbox"/>
		<input type="checkbox"/>	AK5	Russian Maritime Register of Shipping (RMRS) type approval	<input type="checkbox"/>
		<input type="checkbox"/>	AK6	Registro Italiano Navale (RINA) type approval	<input type="checkbox"/>
		<input type="checkbox"/>	AL	Individual inspection by notified body inspector – (body to be indicated):	<input type="checkbox"/>

■ ENQUIRY