

FEATURES

- All SS construction
- Adjustable needle design

APPLICATION

- Reduces dampening effect of process media

Adjustable Needle



STANDARD SPECIFICATIONS

Type	:	Pattern 1 (Adjustable needle)
Material	:	AISI 316 SS
Instrument connection	:	1/2" NPT (F)
Process connection	:	1/2" NPT (M)
Gaskets / Seals	:	Viton
Maximum working pressure	:	400 bar
Maximum working temperature	:	180°C

DIMENSIONAL DRAWING

Pattern 1

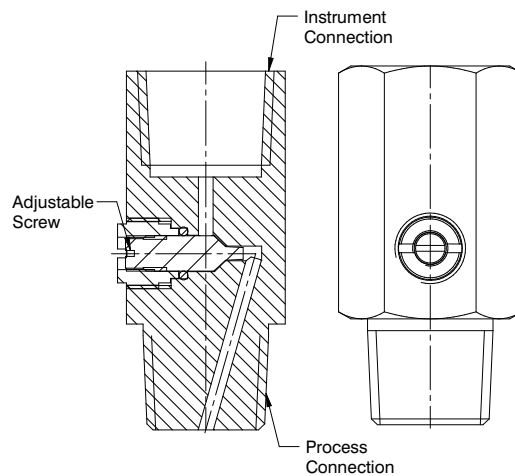

ORDERING CODES

1. TYPE

1	Pattern 1 (Adjustable needle)	1
---	-------------------------------	---

2. MATERIAL

MA	Brass	MF
MC	AISI 304 SS	
MF	AISI 316 SS	
MG	AISI 316L SS	
MM	Monel	
MO	Hastelloy C-276	

3. INSTRUMENT CONNECTION

02B	1/4" BSP (F)	04N
03B	3/8" BSP (F)	
04B	1/2" BSP (F)	
02N	1/4" NPT (F)	
03N	3/8" NPT (F)	
04N	1/2" NPT (F)	
04M	M20x1.5 mm (F)	

4. PROCESS CONNECTION

12B	1/4" BSP (M)	14N
13B	3/8" BSP (M)	
14B	1/2" BSP (M)	
12N	1/4" NPT (M)	
13N	3/8" NPT (M)	
14N	1/2" NPT (M)	
14M	M20x1.5 mm (M)	

5. OTHER OPTIONS

TC	Material test certificate 3.1	XM
TM	Material test certificate 2.2	
TN	Tested to NACE standards	
TO	Certification for Oxygen service	
XM	Marking by engraving	
XL	Marking by laser	

Ordering Example : A201-1-MF-04N-14N-XM

NOTES:

1. Other process connections are available through adaptors.
2. Option TC, TM, TN are not applicable for Material selection of MA.
3. The pressure rating for Material selection MA is 250 bar.