

Thermowell is a safety / protection accessory for the sensor part of the temperature measuring, indicating & controlling instruments in corrosive & high pressure areas. They are applicable in all kind of fluid areas. A critical advantage of the thermowell is that, it provides the media isolation for the purpose of maintenance / replacement of the instruments.

ITEC manufacture various types of thermowells; such as,

1. Threaded/Flanged type
2. Van-stone type
3. Socket-weld/weld-in type
4. Sanitary type
5. Multi-piece type

With reference to the shank design thermowell, further classified into,

1. Straight type
2. Reduced-tip type
3. Partial taper type
4. Taper type

ITEC thermowells are machined in CNCs and Deep Gun-drilling machines and available in a variety of stainless steel types. All welds between the flange & well are full penetration welded.

ITEC manufactures thermowells also in exotic materials like Monel, Hastelloy C, titanium, etc and variety of exotic materials and special grades alloys.

ITEC also provide lining or coating on the well/wetted parts, exotic material overlay on flange RF and sleeves for the wells for its thermowells.

Some of the in-house tests are,

1. Wake frequency calculation
2. Hydrostatic test
3. Dye Penetration test
4. Dimensional check

All other tests are conducted at a third party labs, ITEC provide conformity certificate.

Nomenclature of Thermowell:

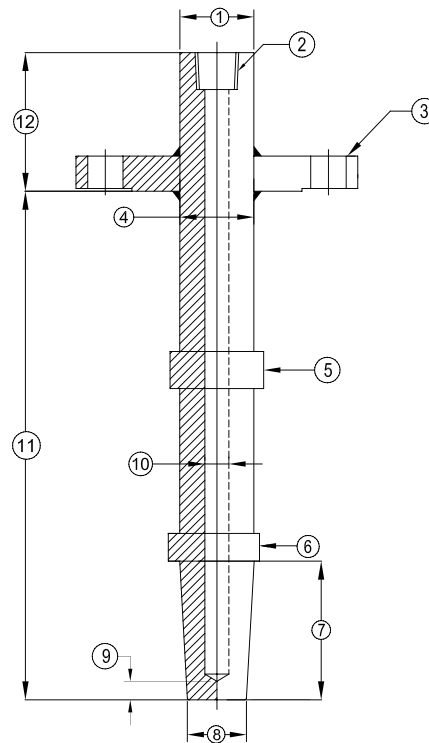

01. Finished head diameter
02. Instrument connection
03. Process connection
04. Major diameter
05. Velocity collar 2 (Optional)
06. Velocity collar 1
07. Reduced tip/taper length
08. Minor diameter
09. Tip thickness
10. Bore diameter
11. Unsupported (U) length
12. Extension length

ASME PTC 19.3TW-2010

The wake frequency calculation for thermowells gives a calculated proof of the strength with respect to static and dynamic stress in relation to the operating temperature and pressure. The standard is divided into dynamic and static calculation results. For gaseous media, a frequency ratio [r] of 0.8 is still valid however there are some cases where this does not apply. For liquid media, for most of the applications, frequency ratio [r] considers a 0.4.

In ITEC, experienced engineers calculate, optimize and issue the Wake Frequency Calculation as per the project requirements.

Resolution for WFC failure

There are mainly 4 ways to tackle the WFC failure. The resolutions are,

1. Shortening the insertion length
2. Increasing the root diameter
3. Increasing the tip diameter
4. Velocity collars

Although the use of Velocity collars has been out of scope of the new standard, many of the existing plants, experienced customers are preferred to use the Velocity collars to have a better sensing. The ideal Velocity collar location is considered as Stub length – 1”. If the result is higher than 5” an additional Velocity collar can be added to lessen the stress effect on the thermowell. A circular or triangular or 4-point collar designs are used as a regular practice.

97/23/EC PED

The applicability of the 97/23/EC Pressure equipment directive in reference to thermowells is explained below in thermowells there is neither a fluid under pressure, nor is there any fluid transported within. Thermowells therefore are not "pressure-containing equipment" within the meaning of the Pressure equipment directive (see guideline 1/40).

Thermowells are components within pressure equipment in accordance with the PED. As such a component, it does not comply with the definition for pressure equipment in article 1, paragraph 2.1 of the PED and does not have to be marked with CE (see guideline 1/22).