

WSP-4

with PNP+NPN output



Vibrating level switch WSP-4 with PNP+NPN output

(technical information)



Table of contents

1. Application
2. Construction
3. Mounting
4. Operating modes
5. Work control
6. Technical data
7. Drawings

1. Application

The vibrating level switches WSP-4 are intended to indicate the limit levels of liquids in pressurized or open containers.

2. Construction

Switch is built from vibrating rods (forks) 1 (Fig. 1 or Fig.4), membrane 2, body 3, electronics housing 4 and connector M12 or ISO4400.

Depending on the destination switches WSP-4 may exist in several different designs:

- WSP-4A - short,
- WSP-4B – elongated,
- WSP-4C – with thermal distance,
- WSP-4D - with the sliding sleeve,
- WSP-4E - extremely long with forks mounted on the wire,
- WSP-4H - hygienic.

This version of the design WSP-4 has a transistor output PNP.

3. Mounting

Switches can be attached to the connector pipe with thread-inch "G", "R", NPT, or metric. On the body is a "P" sign, which determines the orientation of the forks relative to the nut. After screwing the switch, the "P" sign should be oriented so as the forks put up the least resistance to the liquid.

4. Operating modes

WSP-4 switches can operate in one of two modes: minimum - MIN or maximum - MAX. MAX mode, wherein the WSP-4 switch is mounted in the upper part of the tank, it applies the overflow protection. In this mode, when the liquid will cover the forks, the red LED lights up, indicating a state of emergency, and the output remains open as the absence of voltage.

In the MIN mode WSP-4 switch is mounted in the bottom of the vessel. It fulfills the function of protection against dry running, eg. the pump. In this mode, when the liquid falls below the forks, the red LED lights up, indicating a state of emergency and the outputs remain open as the absence of voltage.

Selecting the operating mode of the WSP-4 switch is made by the appropriate connection of supply voltage to the M12 sockets as shown in Figure 2.

5. Work control

While working on the object WSP-4 switch can be controlled by applying a permanent magnet to the enclosure from the side where LEDs are. Under the influence of an applied magnet the output status changes to the opposite. Also the color of the LEDs changes.

6. Technical data

- power supply	10 - 30 VDC
- output	Transistor PNP + NPN
- power consumption	0,76W
- load PNP output	0,2A with overcurrent and overvoltage protection
- load NPN output	0,2A with overcurrent and overvoltage protection
- ambient temperature	-30 °C ÷ 70°C
- process pressure	10 bar
- material	Steel 0H19N9
- IP degree of protection	IP66
- process connections	G= 1/2", 3/4" NPT=1/2" M=20x1,5

7. Drawings

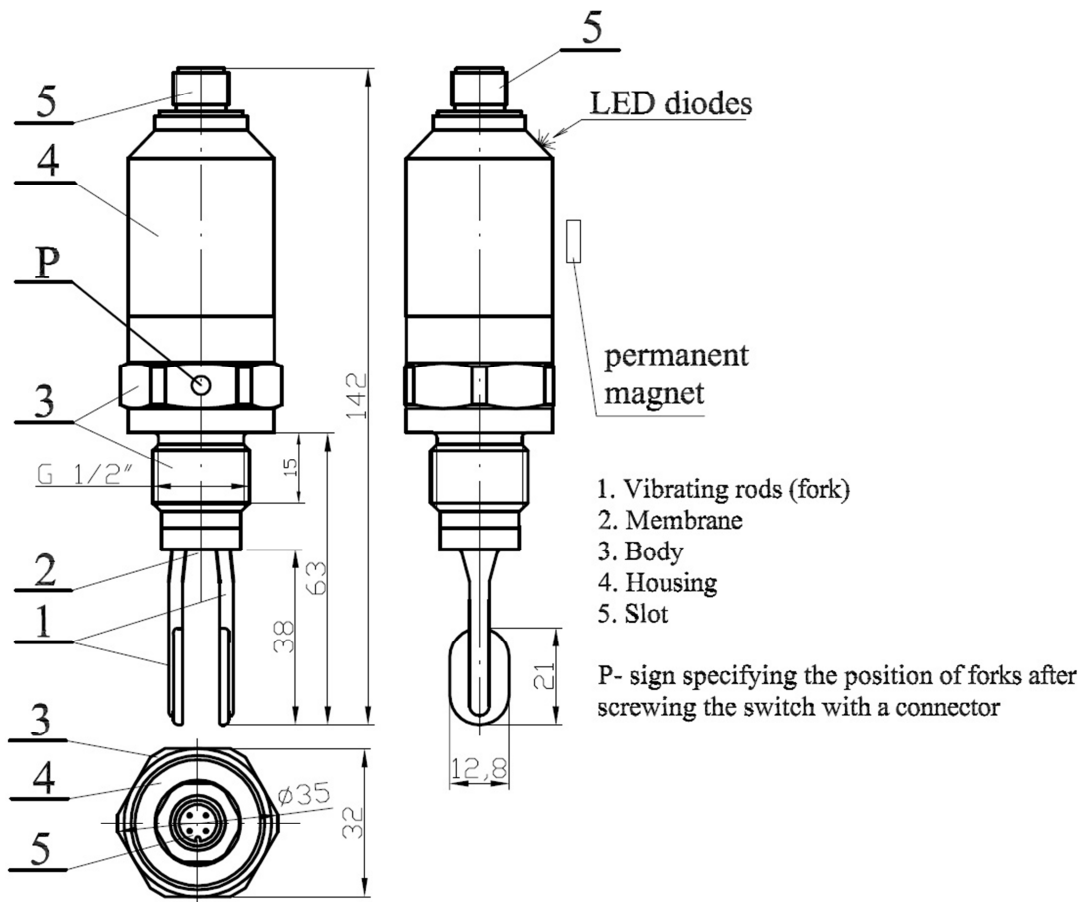
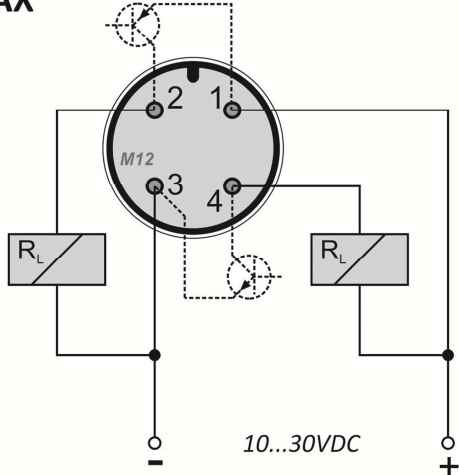

Fig. 1. Vibrating level switch WSP-4A with M12 connector.

Mode **MAX**



Mode **MIN**

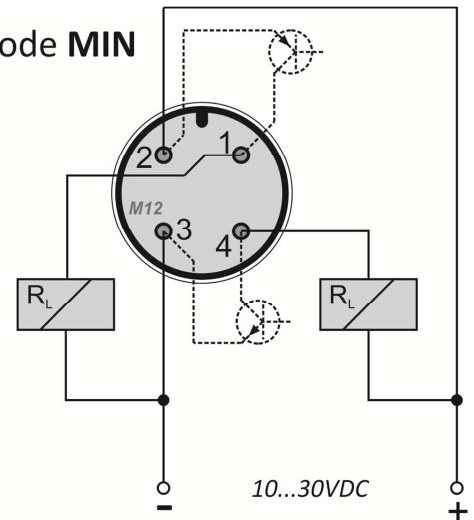

Fig. 2. Selecting the operating mode of the WSP-4 switch with PNP+NPN output.

Operating mode	Level	Output	Control lamp	
			green LED	red LED
upper level detection MAX (overflow protection)		 CLOSED		
		 OPEN		
lower level detection MIN (dry running protection for pump)		 CLOSED		
		 OPEN		

- LED off, - LED on.

Fig. 3. LED indication for switch WSP-4 with PNP+NPN output.