

KA20

Pneumatic & Electric Globe Control Valve
ANSI 600

Manufactured under ISO 9001 quality assurance system, the OMC **KA20** series is a top guided globe valve construction, that can accommodate a wide range of different single stage trims.

KA20 series combines the advanced modular design and a wide range of actuators to satisfy the needs of industrial applications.

KA20 valves are designed to control a broad variety of fluids, including steam, water, air and liquid or gas hydrocarbons. The top guided construction of the KA20 provides precise plug travel over entire stroke of the valve, which minimizing vibration and increases service life.



14/68/EU (PED)
14/34/EU (ATEX)



EAC Conformity
CU TR 010 / CU TR 032



Safety Integrity Level
IEC EN 61508 - TÜV



Fugitive emissions
ISO 15848-1



- ◆ From 1/2" to 8" rating class ANSI 600
- ◆ Top Guided construction to ensure plug stability
- ◆ Designed and engineered for robustness in demanding applications
- ◆ Modular design
- ◆ CEI EN 60534-6-1 Clamp and Yoke Std.
- ◆ Std. self adjusting double packing spring loaded
- ◆ Shutoff capabilities : Class IV (std.) , V, VI

OPTIONS

Reduced area trim to provide wide capabilities for all sizes

Hardened trims to handle high pressure drop applications

Balanced trims to handle high pressure drop & shutoff

“Quick-Change” seat ring

Low noise & anticavitation design cage

Bellows seal to meet zero emissions (ZEB20)

Bonnet for low temperature and for high temperature

Full St.Steel actuator construction

BW / SW / RTJ connections & special on request

Heating jacket



REFERENCE STANDARDS

Quality system management certification	ISO 9001
Design std.	ANSI B16.34
Flange connection	ANSI B16.5
Socket-Welding Ends	ANSI B16.11
Buttwelding Ends	ANSI B16.25
Pressure Rating	ANSI Class 600
Face to face dimension	ANSI / ISA 75.08.01
Seat tightness Class	ANSI FCI 70.2 - IEC 60534-4
Positioner mounting	CEI EN 60534-6-1
2014/68/EU (PED) Certification	Module B + C2
Mechanical resistance calculation method	EN 12516-2
Hydrostatic pressure test	ANSI B16.34
Pressure / Temperature relationship	ANSI B16.34
2014/34/EU (ATEX) Conformity	II 2 G Ex h IIC T6...T1 Gb II 2 D Ex h IIIC T6...T1 Db
Non-electrical equipment for explosive atmospheres Basic method and requirements	EN ISO 80079-36
Safety Integrity Level (SIL)	IEC EN 61508
Safety Integrity Level (SIL) Approval	SIL 3 - (C-IS-722133629)
Fugitive emissions Certification	ISO 15848-1
EAC Conformity	CU TR 010 / CU TR 032
NACE	MR0175

STD VALVE BODY CHARACTERISTICS

Style	Top entry, single seated, globe valve
Sizes	from 1/2" to 8"
Pressure rating	ANSI Class 600
Design std.	ANSI B16.34
Flange connection	ANSI B16.5 - Raised Face - Phonography serrated 125-250 AARH
Face to face dimensions	ANSI / ISA 75.08.01

STD BODY & TRIM MATERIALS COMBINATION

VALVE BODY (1)	BONNET (9)	TRIM (2 and 3)	STUD	NUTS	BODY GASKET (11)
Carbon steel A216 WCC	ASTM A105	ASTM A182 F316	A193 B7	A194 H2	Graphite + Stainless steel
Stainless steel A351 CF8M	ASTM A182 F316	ASTM A182 F316	A193 B8M	A194 8M	Graphite + Stainless steel

CONSTRUCTION EXAMPLES

1. Valve body
2. Seat ring
3. Plug
6. "Top Guide" stem
9. Bonnet
10. Stuffing box
11. Body gasket

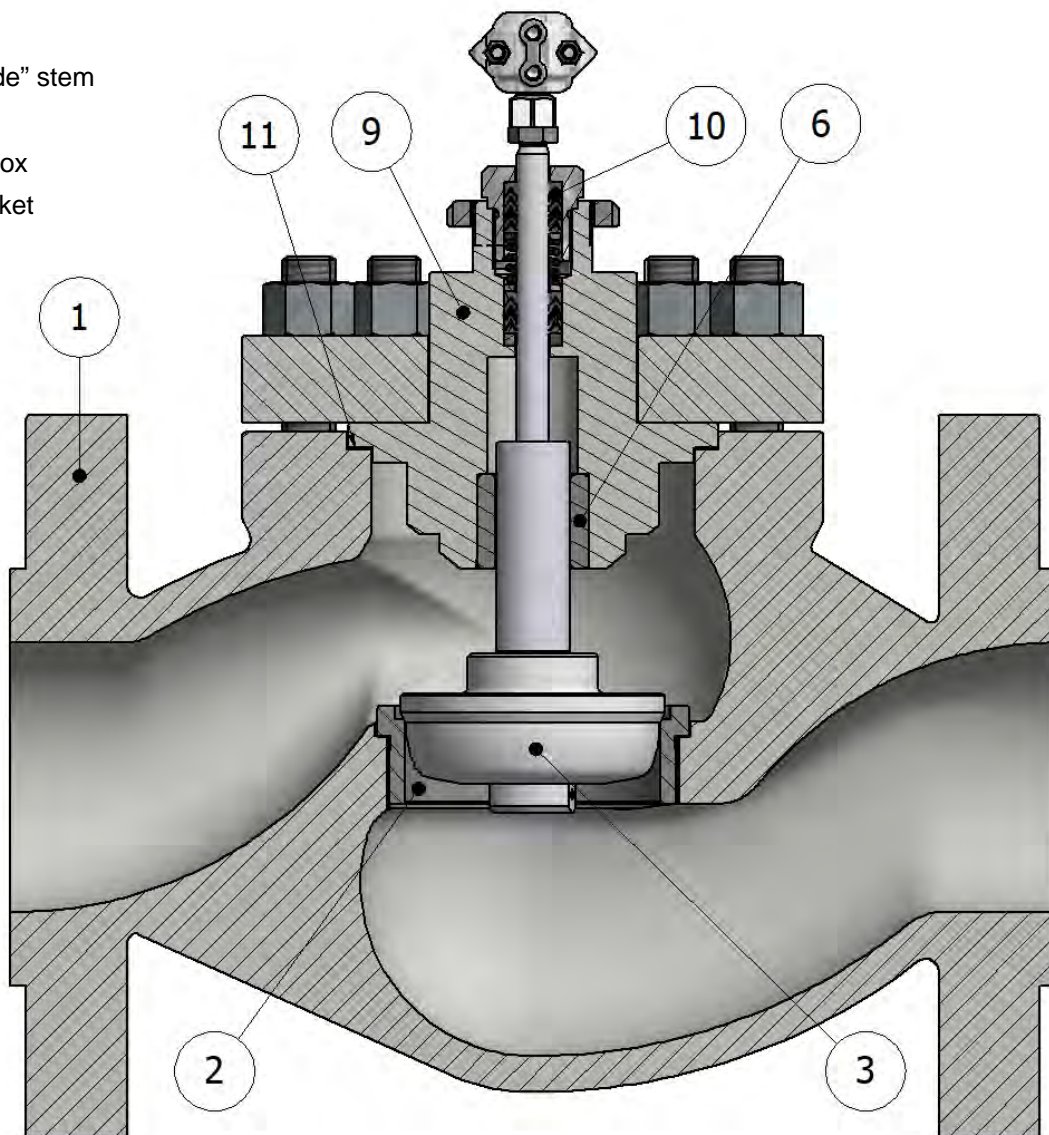

STANDARD VALVE

CONSTRUCTION EXAMPLES

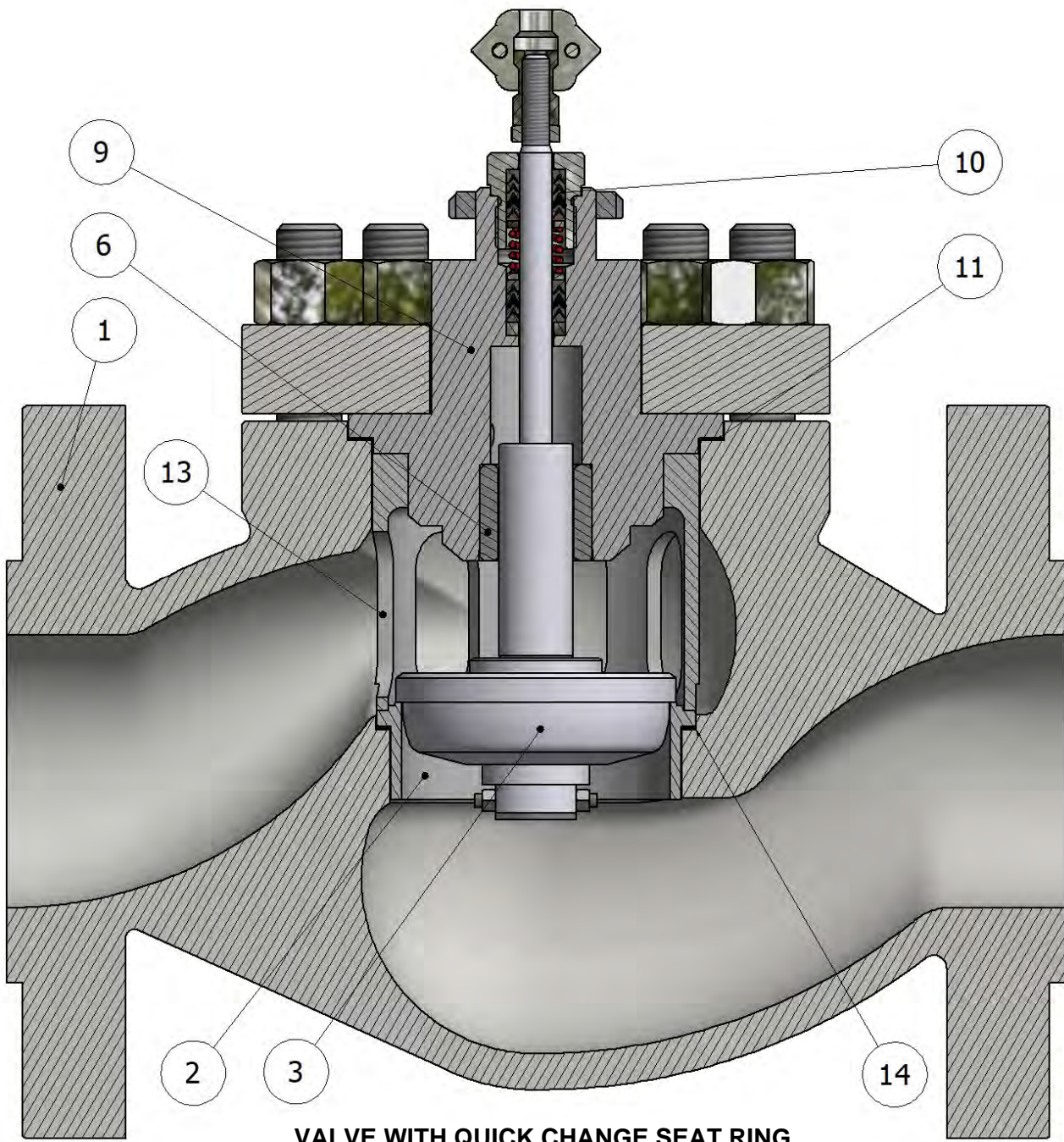

VALVE WITH QUICK CHANGE SEAT RING

- 1. Valve body
- 2. "Quick Change" seat ring
- 3. Plug
- 6. "Top Guide" stem
- 9. Bonnet
- 10. Stuffing box
- 11. Body gasket
- 13. Seat retainer
- 14. Seat gasket

Unlike the standard seat, the "Quick-Change" seat (2) is not screwed up but is blocked by the part (13). This guarantees a quick field replacement without the use of special equipment

CONSTRUCTION EXAMPLES

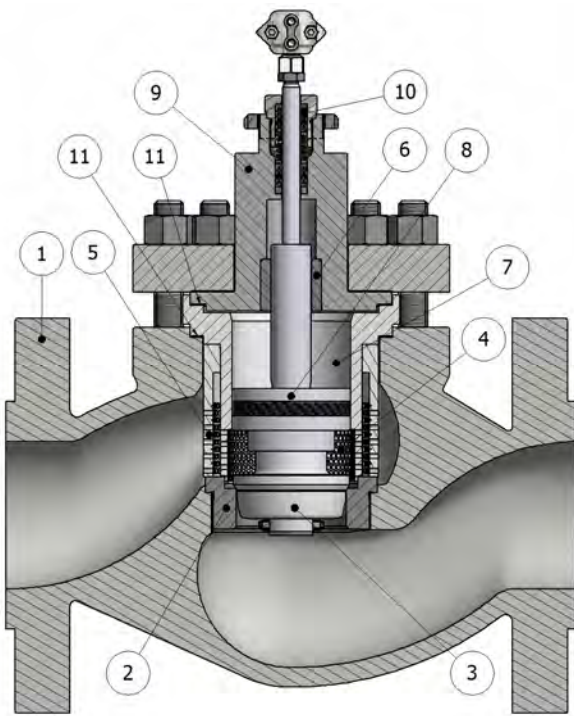

**BALANCED TRIM VALVE
WITH DOUBLE CAGE NOISE
REDUCTION**

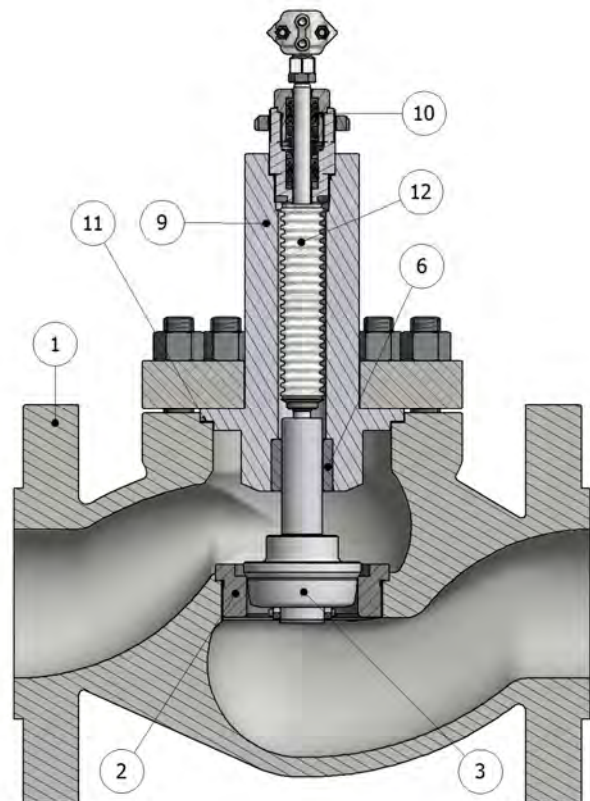

VALVE WITH BELLOWS

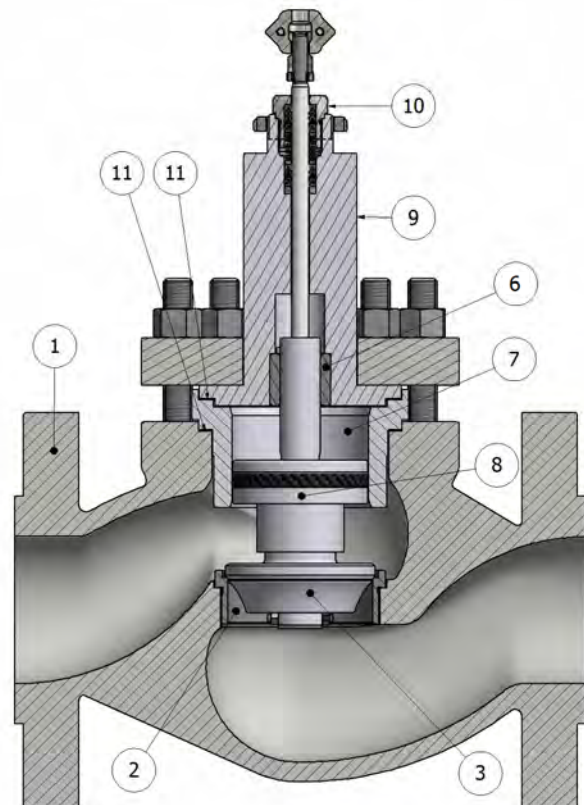

**BALANCED TRIM VALVE WITH
EXTENDED BONNET**

- 1. Valve body
- 2. Seat ring
- 3. Plug
- 4. 1st stage low dB Cage
- 5. 2nd stage low dB Cage
- 6. Top-guide stem
- 7. Balancing sleeve
- 8. Balancing piston
- 9. Bonnet
- 10. Stuffing box
- 11. Body Gasket
- 12. ZEB20 Bellows

WORKING PRESSURE BY CLASS STD MATERIALS (ASME B16.34)

OPERATING TEMPERATURE		ASTM A105 (-20.2° ÷ 797°F)	ASTM A216 WCC (-20.2° ÷ 797°F)	A351 CF8M / A182 F316 (-423.4° ÷ 1500°F)
°F	°C	bar	bar	bar
100,4	... ÷ 38	102.1	103.4	99.3
122	50	100.2	103.4	95.5
212	100	93.2	103.0	81.7
302	150	90.2	100.3	74.0
392	200	87.6	97.2	69.0
482	250	83.9	92.7	65.0
572	300	79.6	85.7	61.8
617	325	77.4	82.6	60.4
662	350	75.1	80.0	59.3
707	375	72.7	75.7	58.1
752	400	69.4	69.4	56.9
797	425	57.5	57.5	56.0
842	450	—	—	54.8
887	475	—	—	53.9
932	500	—	—	53.0
1000	538	—	—	48.9
1022	550	—	—	47.1
1067	575	—	—	41.7
1112	600	—	—	33.8
1157	625	—	—	27.6
1202	650	—	—	22.5
1247	675	—	—	18.7
1292	700	—	—	16.1
1337	725	—	—	13.5
1382	750	—	—	11.6
1427	775	—	—	9.0
1472	800	—	—	7.0
1500	816	—	—	5.9

MATERIALS AVAILABLE ON REQUEST

Carbon steel	A352 LC2; A352 LC3; A352 LCC; A352 LCB
Alloy Carbon Steel	A217 WC6; A217 WC9
Austenitic Stainless Steel	A351 CF3; A351 CF8; A351 CF10; A351 CF3M; A351 CF8M; A351 CF10M
Ferritic Austenitic Stainless Steel (DUPLEX / SUPERDUPLEX)	A995 CD3MWCuN; A995 A6; A351 CK3MCuN; A351 CE8MC; A351 CD3MN; A351 CD4MCuN
Nickel Alloy Stainless Steel	A494 M35-1 (MONEL); A494 M35-2 (MONEL); A494 N-12MV (HASTELLOY B); A494 CW-12MW (HASTELLOY C)
STUD & NUTS	In according to the body material

STANDARD PROTECTIVE COATING

WORKING TEMPERATURE	VALVE BODY	BONNET
from -20° to 302°F from -29° to 150°C	<ul style="list-style-type: none"> • Bicomponent anticorrosive acrylic primer at high resistance • Finish with bicomponent aliphatic acrylic enamel RAL 7021 opaque 	Electrolytic zinc coatings Fe/Zn 8 c1A UNI ISO 4520
from 302° to 482°F from 150° to 250°C	<ul style="list-style-type: none"> • Siliconic primer • Finish with siliconic enamel RAL 9005 	Electrolytic zinc coatings Fe/Zn 8 c1A UNI ISO 4520
from 482° to 752°F from 250° to 400°C	<ul style="list-style-type: none"> • Heat resistant siliconic primer • Finish with siliconic enamel RAL 9006 	

PNEUMATIC ACTUATOR STANDARD PROTECTIVE COATING

CASING AND YOKE

Polyester electrostatic epoxy powder coating - RAL 7032



RAL 7021



RAL 9005

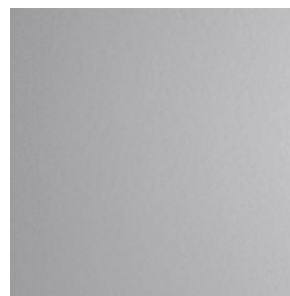

RAL 9006



RAL 7032

Colors and shades shown in the figure are indicative

PROTECTIVE COATING ON REQUEST

Customer specification colors

Painting for sea environment



Painting in according to ISO 12944

Painting in according to NORSOK M-501

NACE - FROSIO painting

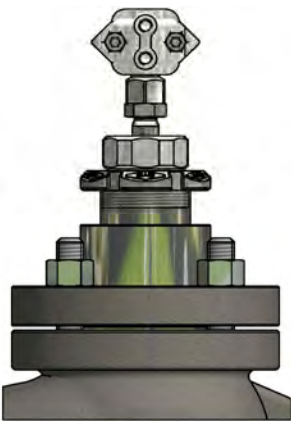

BONNET TYPES

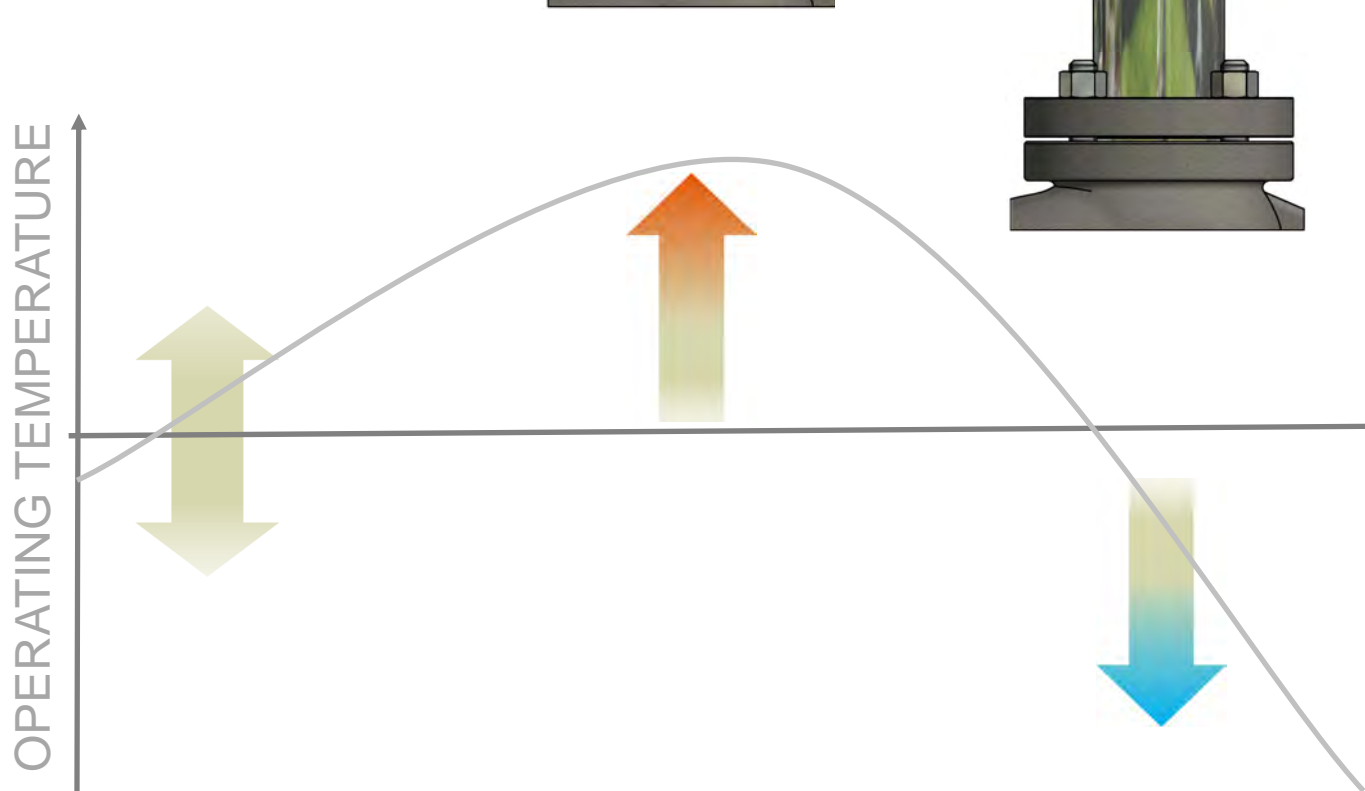
STANDARD	FINNED	EXTENDED
<p>The standard bonnet is cast or forged from the same or equivalent grade of material as the valve body. It is suitable for applications with temperatures between</p> <p style="text-align: center;">23°F ÷ 428°F (-5°C ÷ 220°C)</p> 	<p>The finned bonnet is cast or forged from the same or equivalent grade of material as the valve body.</p> <p>Engineered for high temperature applications the fins dissipate heat and protect valve stem packing from extreme process temperatures up to 392°F (+200°C)</p> <p style="text-align: center;">23°F ÷ 1112°F (-5°C ÷ 600°C)</p> 	<p>The extended bonnet is cast or forged from the same or equivalent grade of material as the valve body.</p> <p>To protect the stem packing the extended bonnet traps some process fluid. This provides a thermal buffer between the packing and the low temperature process fluid.</p> <p>Engineered for low temperatures, the extension length is manufactured to suit the applications where minimum temperature medium is below 23°F (-5°C).</p> <p style="text-align: center;">-320°F ÷ 428°F (-196°C ÷ 220°C)</p> 
 <p>OPERATING TEMPERATURE</p>		

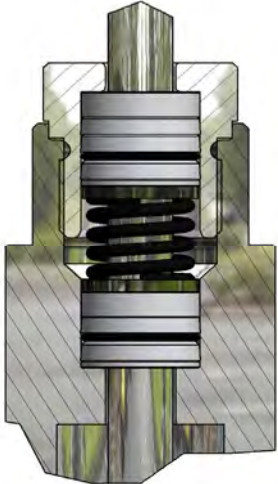
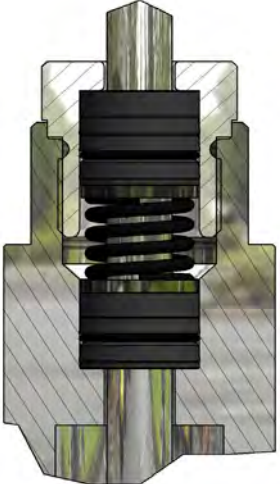
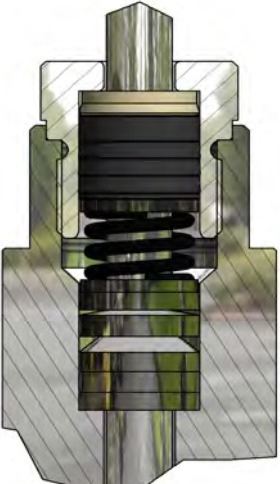
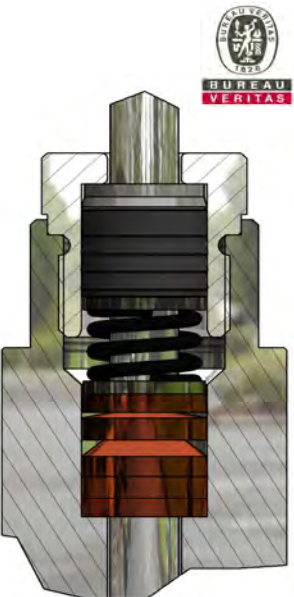

PACKING TYPES - VALVES FROM ½" UP TO 4"

LP200	SP200	HP300	ECOPACK 1
<p>It consists of a series of energized V ring pack in Virgin PTFE and FKM, especially used with Oxygen and Cryogenic applications.</p> <p>Self-adjusting and maintenance free.</p>	<p>It consists of a series of energized V ring pack in PTFE base & FKM 75 Shore. Suitable for low & medium temperature application.</p> <p>Self-adjusting and maintenance free.</p>	<p>Directly in contact with the medium it consists of a series of energized V ring pack in Graphite and PTFE. Especially used for high temperature applications.</p> <p>Self-adjusting and maintenance free.</p>	<p>Made of a series of energized V ring pack in Graphite/PTFE. ISO 15848-1 Certified for Low emission fugitive test.</p> <p>Self-adjusting and maintenance free.</p>
			

PACKING / BONNET TEMPERATURE CORRELATION

	LP200	SP200	HP300	ECOPACK 1
CRYOGENIC BONNET	-320 ÷ 356°F -196 ÷ 180°C	///	///	-320 ÷ 356°F -196 ÷ 180°C
EXTENDED BONNET	-130 ÷ 356°F -90 ÷ 180°C	-130 ÷ 428°F -90 ÷ 220°C	///	-130 ÷ 428°F -90 ÷ 220°C
STANDARD BONNET	23 ÷ 356°F -5 ÷ 180°C	23 ÷ 428°F -5 ÷ 220°C	///	23 ÷ 428°F -5 ÷ 220°C
FINNED BONNET	///	23 ÷ 500°F -5 ÷ 260°C	23 ÷ 752°F -5 ÷ 400°C	23 ÷ 752°F -5 ÷ 400°C
EXTENDED FINNED BONNET	///	///	23 ÷ 1112°F -5 ÷ 600°C	///
EXTENDED BONNET FOR BELLOWS	///	-130 ÷ 500°F -90 ÷ 260°C	23 ÷ 752°F -5 ÷ 400°C	-130 ÷ 752°F -90 ÷ 400°C
EXTRA EXTENDED BONNET	-320 ÷ 356°F	///	23 ÷ 1112°F	///

PACKING TYPES - VALVES FROM 6" UP TO 8"

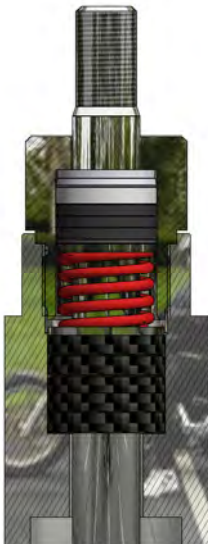
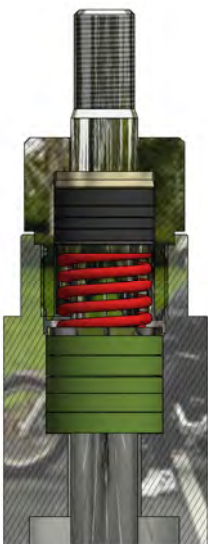
LP400	SP400	HP600	ECOPACK 2
<p>It consists of a series of energized V ring pack in Virgin PTFE and FKM, especially used with Oxygen and Cryogenic applications.</p> <p>Self-adjusting and maintenance free.</p>	<p>It consists of a series of energized V ring pack in PTFE base & FKM 75 Shore. Suitable for low & medium temperature application.</p> <p>Self-adjusting and maintenance free.</p>	<p>Directly in contact with the medium it consists of a series of energized V ring pack in Graphite and PTFE. Especially used for high temperature applications.</p> <p>Self-adjusting and maintenance free.</p>	<p>Made of a series of energized V ring pack in Graphite/PTFE. ISO 15848-1 Certified for Low emission fugitive test.</p> <p>Self-adjusting and maintenance free.</p>
			

PACKING / BONNET TEMPERATURE CORRELATION

	LP400	SP400	HP400	ECOPACK 2
CRYOGENIC BONNET	-320 ÷ 356°F -196 ÷ 180°C	///	///	-320 ÷ 356°F -196 ÷ 180°C
EXTENDED BONNET	-130 ÷ 356°F -90 ÷ 180°C	-130 ÷ 428°F -90 ÷ 220°C	///	-130 ÷ 428°F -90 ÷ 220°C
STANDARD BONNET	23 ÷ 356°F -5 ÷ 180°C	23 ÷ 428°F -5 ÷ 220°C	///	23 ÷ 428°F -5 ÷ 220°C
FINNED BONNET	///	23-500°F -5-260°C	23 ÷ 752°F -5 ÷ 400°C	23 ÷ 752°F -5 ÷ 400°C
EXTENDED FINNED BONNET	///	///	23 ÷ 1112F -5 ÷ 600°C	///
EXTENDED BONNET FOR BELLOWS	///	-130 ÷ 500°F -90 ÷ 260°C	23 ÷ 752°F -5 ÷ 400°C	-130 ÷ 752°F -90 ÷ 400°C
EXTRA EXTENDED BONNET FOR BELLOWS	-320 ÷ 356°F -196 ÷ 180°C	///	23 ÷ 1112F -5 ÷ 600°C	///

ZEB20 BELLOWS FOR DANGEROUS FLUID

ZEB20 is specifically designed for industrial applications where the possible leakage of process fluid from the packing can cause environmental or personal damage and in extreme cases be hazardous to health.

The ZEB20 is manufactured by welding a bellows to the plug stem and valve bonnet. This removes potential leakage paths, while allowing full movement of the stem. The design provides total isolation of the fluid from the outside environment.

The ZEB20 also includes secondary stem seals as a safety function. These only operate in the unlikely event that a bellows ruptures. The secondary seals will provide reduced risk.

The standard of the bellows material is AISI 316L but, it is also available in in other materials, including Inconel, Monel, Hastelloy, etc...

For safety critical applications the ZEB20 can be fitted with a test connection to allow the addition of feedback devices that monitor the integrity of the bellows.

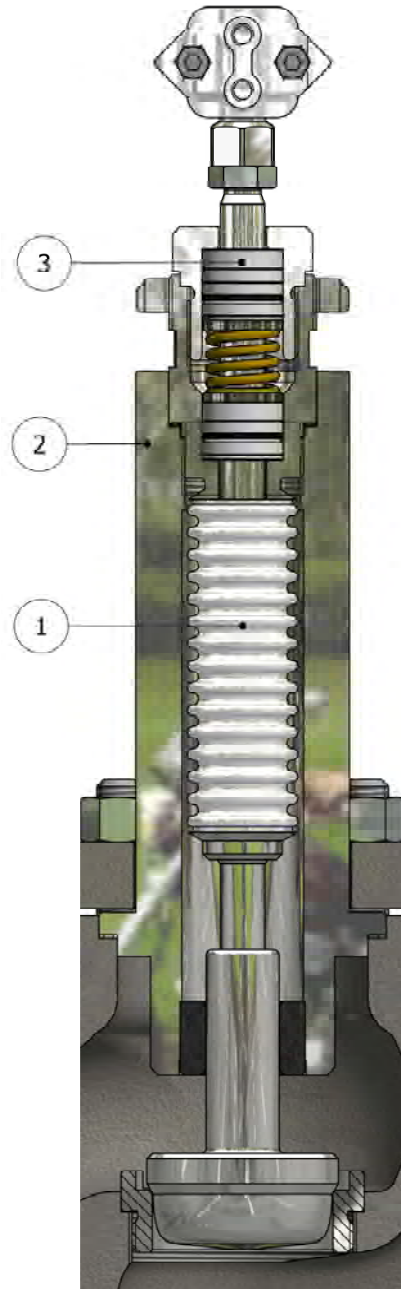

**Fugitive emissions
ISO 15848-1**

ZEB20 MATERIALS COMBINATION

POS.	DESCRIPTION	STD MATERIALS	ON REQUEST	TEMPERATURE
1	Bellows	AISI 316L	Inconel, Monel, Hastelloy, or other materials	-320 + 1112°F -196°C + 600°C
2	Bonnet	Equal or equivalent to the material of the body valve	Other materials	-320 + 1112°F -196°C + 600°C
3	Packing	See packing type chapter		

CONTROL CHARACTERISTICS

QUICK OPENING	LINEAR	EQUAL PERCENTAGE
<p>A valve with quick opening flow characteristic provides a maximum change in flow rate at low travels and small changes when the valve plug is near maximum. Control valves with quick opening flow characteristics are often used for on/off applications where significant flow rate must be established quickly as the valve begins to open. Consequently they are often used in relief valve applications. Quick opening valves can also be selected for many of the same applications for which linear flow characteristics are recommended.</p>	<p>A valve with linear characteristic provide a flow rate directly proportional to travel. Linear characteristics are commonly specified for liquid-level and flow-control applications.</p>	<p>In equal percentage flow characteristic, equal increments of valve travel produce equal percentage changes in the existing flow. A valve with an inherent equal percentage flow characteristic provides precise throttling control through the lower portion of the travel range and rapidly increasing capacity as the valve plug nears the wide open position. Valves with equal percentage flow characteristics are used on pressure control applications, on applications where a large percentage of the pressure drop is normally absorbed by the system itself with only a relatively small percentage available at the control valve, and on applications where highly varying pressure drop conditions can be expected.</p>

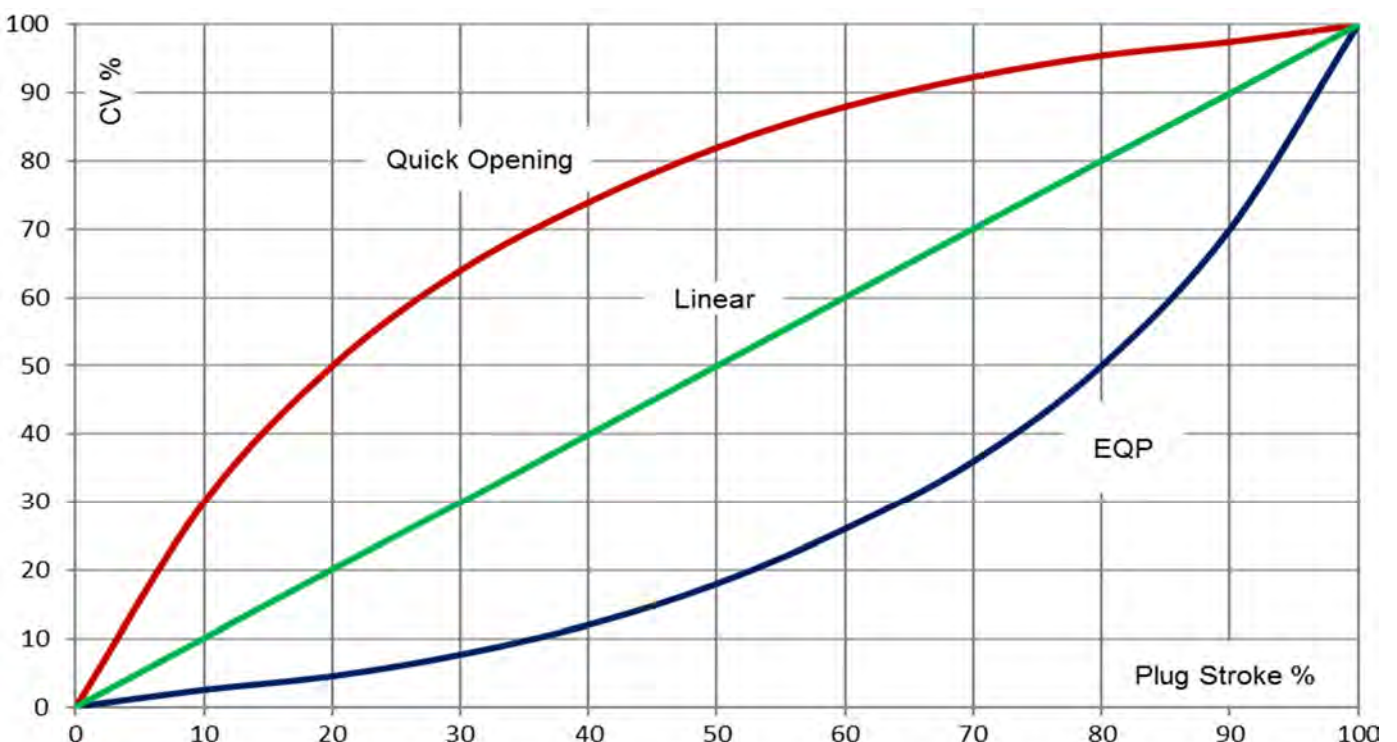

TRIMS CHARACTERISTICS

	STANDARD	ON REQUEST
CONTROL CHARACTERISTICS	Equal Percentage (EQP)	Quick opening (ON-OFF)
		Linear (PL)
PORT	Full port	Reduced port
		Microflow port
SEAL	Metal seat tightness Class IV	Stellite faced seat/plug Class IV
		Saline nitriding (QPQ) seat/plug Class IV
		Stellite faced seat/plug Class V - Lapped
		Lapped seat/plug Class V
		PTFE soft seal <300°F (150°C) - Class VI
		PTFE-GR soft seal <375°F (190°C) - Class VI
		PEEK Soft seal <536°F (280°C) - Class VI

LINEAR SPLINE PLUG	QUICK OPENING PLUG	EQP PLUG METAL TIGHTNESS	EQP PLUG SOFT TIGHTNESS
			

BALANCED PLUG CONSTRUCTION

In applications where there is a high flow rate and a high pressure drop valve actuators can struggle to provide tight shut off against the force of the upstream pressure on the plug. In these applications the balanced plug option redirects some of the upstream pressure to balance the influence of the pressure drop across the plug.

This results in a more efficient actuator thrust for a particular size of actuator. This ensures the tightness class of the valve.

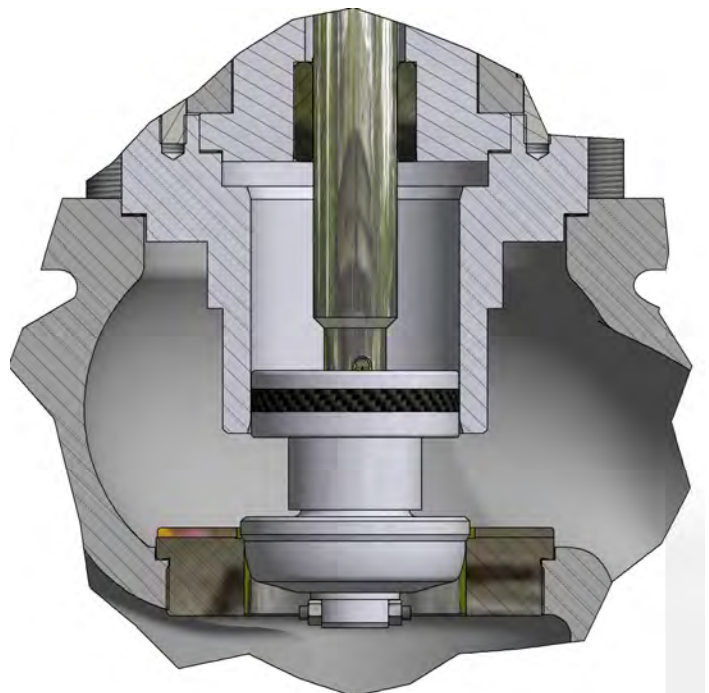
BALANCED TRIM

CAVITATION, FLASHING EFFECT NOISE LEVEL

The globe valve allows the regulation of a parameter which can be the pressure or flow going to modify the flow of pressurized fluid in the system. The principle used is that of the Bernoulli law or the continuity of the fluids. In a globe valve, if I decrease the passage section, the speed increases while the pressure decreases. If this pressure falls below the vapor pressure of the bubbles could be created that could produce two flow disturbance phenomena: Cavitation effect and Flashing effect

Cavitation consists of rapid vaporization and condensation within a liquid. When local pressure falls to vapor pressure (approximately 0.25 psi / 0.018 bar absolute for cold water), vapor bubbles are formed and when these bubbles travel to an area of higher pressure, the bubbles collapse with phenomenal force and great localized stress. It is the violent collapse of these vapor bubbles near valve components or downstream piping surfaces, which cause cavitation damage and subsequent performance degradation. Typically, the reason for low pressure is that the pressure drop across a control valve has created very high velocity in the seat area and corresponding low pressure because potential (pressure) energy is reduced to compensate for the increase in kinetic energy. The principle can be applied to various types of fluid flow and simply states that when there is an increase in the velocity of fluids then it must be accompanied by a decrease in the fluid's pressure, the total energy associated with the flow must remain constant.

The **Flashing** effect is similar to cavitation, except that bubbles explode downstream of the valve.

In control valves, the pressure drop typically occurs at or near the seat area or just downstream. The shock waves and pressure fluctuations resulting from these high velocity bubble collapses can also cause noise, vibrations, accelerated corrosion, as well as limited valve flow. Typically the cavitation is formed in the valve throttling area, the pressure fluctuations radiate into the downstream pipe as noise

The KA20 Series can be equipped with anticavitation and or low noise trims to reduce the possibility of cavitation and noise.



ANTICAVITATION CAGE



LOW dB TRIM SINGLE STAGE

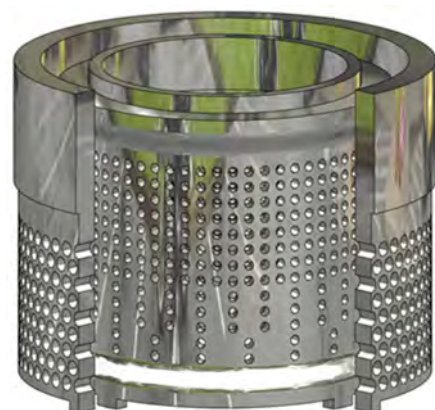

LOW dB TRIM DOUBLE STAGE

EQUAL PERCENTAGE PLUG FLOW RATE COEFFICIENTS SEAT BORE DIAMETER AND STROKE

CV	Kv	Seat bore diameter		Std plug stroke		Valve size									
		inch	mm	inch	mm	1/2"	3/4"	1"	1 1/2"	2"	3"	4"	6"	8"	
0.08	0,07	0.12	3	0.79	20	□	□	□	□	□	—	—	—	—	
0.20	0,17	0.15	4			□	□	□	□	□	—	—	—	—	—
0.60	0,51	0.20	5			□	□	□	□	□	—	—	—	—	—
1.00	0,85	0.27	7			□	□	□	□	□	—	—	—	—	—
1.3	1,11	0.31	8			□	□	□	□	□	—	—	—	—	—
1.8	1,54	0.35	9			□	□	□	□	□	—	—	—	—	—
2	1,7	0.39	10			□	□	□	□	□	—	—	—	—	—
2.5	2,15	0.39	10			□	□	□	□	□	□	—	—	—	—
3	2,58	0.39	10			□	□	□	□	□	□	□	—	—	—
3.5	3	0.39	10			□	□	□	□	□	□	□	—	—	—
5.5	4.7	0,59	20			■	□	□	□	□	□	□	—	—	—
8	6,8	0,79	20			—	■	□	□	□	□	□	□	—	—
13	11	0,98	25			—	—	■	□	□	□	□	□	—	—
19	16	1,18	30			—	—	—	□	□	□	□	□	□	—
29	25	1,50	38			—	—	—	■	□	□	□	□	□	□
50	43	1,93	49			—	—	—	—	■	□	□	□	□	□
75	64	2,52	64	1.18	30	—	—	—	—	—	□	□	□	□	
112	96	2,99	76			—	—	—	—	—	—	■	□	□	□
173	148	3,94	100	1.38	35	—	—	—	—	—	—	■	□	□	
190	162	3,94	100			—	—	—	—	—	—	—	□	□	□
270	231	4,96	126	2.00	50	—	—	—	—	—	—	—	□	□	
410	351	5,94	151			—	—	—	—	—	—	—	—	■	□
720	615	7,91	201	2.36	60	—	—	—	—	—	—	—	—	■	

— not available ■ standard □ on request

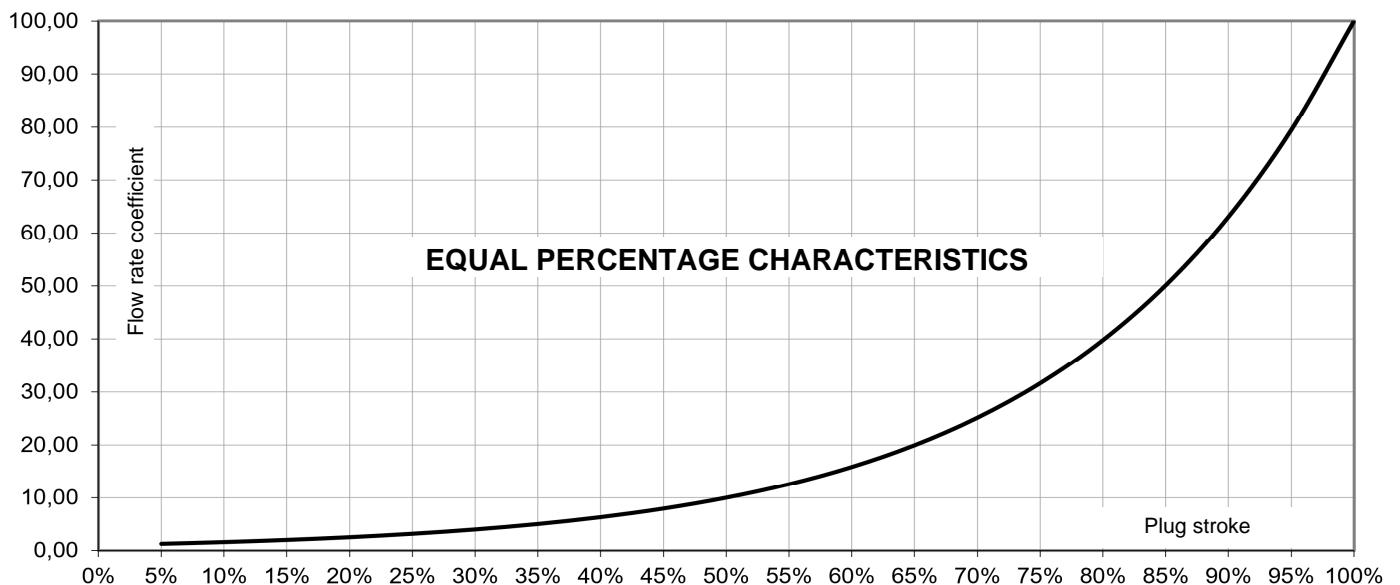

LINEAR & QUICK OPENING PLUG FLOW RATE COEFFICIENTS SEAT BORE DIAMETER AND STROKE

CV	Kv	Seat bore		Std plug		Valve size									
		inch	mm	inch	mm	1/2"	3/4"	1"	1 1/2"	2"	3"	4"	6"	8"	
0.03	0,02	0.12	3	0.79	20	□	□	□	□	□	—	—	—	—	
0.05	0,04	0.12	3			□	□	□	□	□	—	—	—	—	
0.08	0,07	0.12	3			□	□	□	□	□	—	—	—	—	
0.20	0,17	0.15	4			□	□	□	□	□	—	—	—	—	
0.60	0,51	0.20	5			□	□	□	□	□	—	—	—	—	
0.75	0,65	0.23	6			□	□	□	□	□	—	—	—	—	
1.00	0,85	0.27	7			□	□	□	□	□	—	—	—	—	
1.3	1,11	0.31	8			□	□	□	□	□	—	—	—	—	
1.8	1,54	0.35	9			□	□	□	□	□	—	—	—	—	
2	1,7	0.39	10			□	□	□	□	□	—	—	—	—	
2.5	2,15	0.39	10			□	□	□	□	□	□	—	—	—	
3	2,58	0.39	10			□	□	□	□	□	□	—	—	—	
3.5	3	0.39	10			□	□	□	□	□	□	—	—	—	
6	5,1	0,59	20			■	□	□	□	□	□	□	—	—	
8	6,8	0,79	20			—	■	□	□	□	□	□	—	—	
13	11	0,98	25			—	—	■	□	□	□	□	—	—	
19	16	1,18	30			—	—	—	□	□	□	□	□	—	
29	25	1,50	38			—	—	—	—	■	□	□	□	□	
50	43	1,93	49			—	—	—	—	—	■	□	□	□	
75	64	2,52	64			—	—	—	—	—	—	□	□	□	
112	96	2,99	76	1.18	30	—	—	—	—	—	■	□	□		
173 ^a	148	3,94	100			—	—	—	—	—	—	—	■	□	
190	162	3,94	100	1.38 ^b	35 ^b	—	—	—	—	—	—	□	□		
280	239	4,96	126	2.00	50	—	—	—	—	—	—	—	□	□	
435	372	5,94	151			—	—	—	—	—	—	—	—	—	■
720	615	7,91	201	2.36	60	—	—	—	—	—	—	—	—	—	■

— not available

■ standard

□ on request

a) not available for quick opening characteristic

b) 1.18" (30mm) for quick opening characteristic

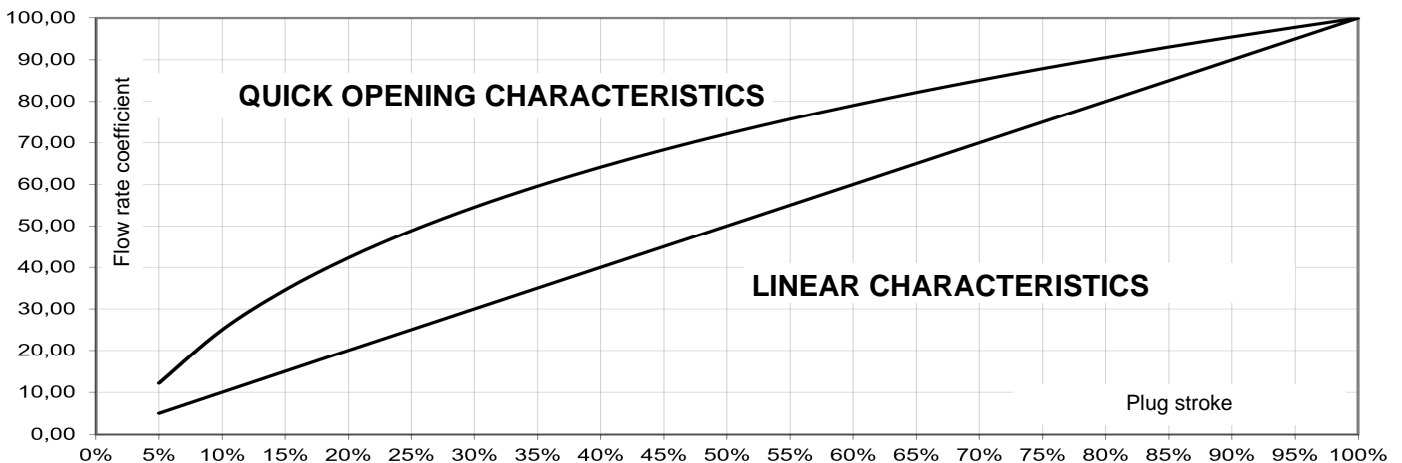

AP SERIES PNEUMATIC ACTUATORS - SPECIFICATIONS

AP series pneumatic actuators are multi diaphragm actuators. They are Available with four (4) different sizes of internal diaphragms. They are extremely compact and they can guarantee a perfect linearity to satisfy the control needs of the valves at different working pressures. They are equipped with an industry standard yoke (CEI EN 60534-6-1), which ensures accessories can be fitted quickly and easily. A full range E/P positioners, solenoid valves, limit switch boxes and feedback devices are available as option. As you standard a mechanical travel indicator and index scale are included as standard on all actuators.

TECHNICAL DATA

TYPE	Diaphragm type - multispring	
CONTROL SIGNAL	Direct Action (Air to close - valve normally open) 6÷18psi; 6÷30psi; 15÷60psi Reverse (Air to open - valve normally closed) 6÷18psi; 6÷30psi; 15÷60psi	3÷15psi ; 3÷15psi ;
MAX AIR SUPPLY PRESSURE	50 psi (3,5bar) for signals 3÷15psi ; 6÷18psi; 6÷30psi; 87 psi (6 bar) for signal 15÷60 psi	
PNEUMETIC CONNECTION	1/4" NPF-F	

MATERIALI

	STANDARD	ON REQUEST
YOKE	ASTM A216 WCB (T.amb \geq -29°C)	Stainless steel ASTM A351 CF8 (T.amb \geq -268°C)
HOUSING	Steel 1.0332 / 1.0335 (T.amb \geq -50°C)	Stainless steel AISI 304 (T.amb \geq -268°C)
	ASTM A216 WCB (*) (T.amb \geq -29°C)	Stainless steel ASTM A351 CF8 (*) (T.amb \geq -268°C)
BOLTS AND NUTS	A193 B7 - A194 2H (T.amb \geq -30°C)	A193 8M - A194 8M (T.amb \geq -268°C)
DIAPHRAGM	NBR (T.amb -35÷90°C)	EPDM (T.amb -50÷120°C) PVMQ (T.amb -60÷90°C)
SPLINDE	ASTM 182 F304	//
VALVE CLAMP CONNECTION	ASTM A 351 CF8	//
SPRING	EN 10270-1 SH painted (T.amb \geq -30°C)	EN 10270-3 1.4310 (AISI 301) EN 10270-3 1.4401(AISI 316) (T.amb \geq -268°C)
INTERNAL PARTS	Zinc plated Steel 1.0332 / 1.0335 (T.amb \geq -50°C)	Stainless steel AISI 304

(*) Actuators Series AP6.. only

1. Casing
2. Spring
3. Diaphragm
4. Splinde
5. Integral yoke
6. Valve clamp connection
7. Stroke indicator
8. Diaphragm plate

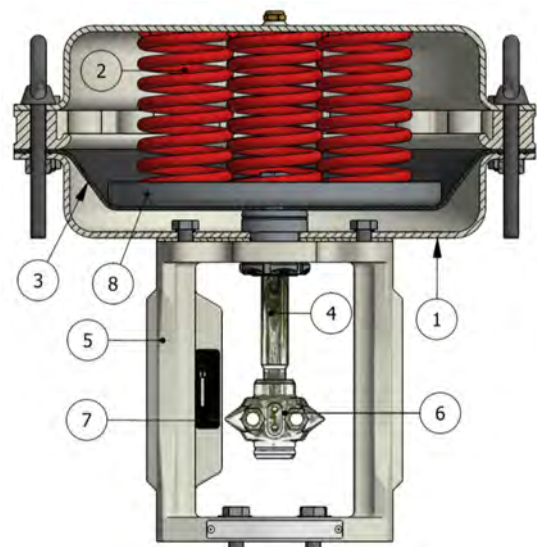

**MAXIMUM ADMISSIBLE PRESSURE DROPS IN bar (FLUID OPEN)
FOR UNBALANCED CONSTRUCTION**

ACTUATOR	THRUST kN	Signal (psi)	CV 5.5 CV 6.0		CV 8		CV 13		CV 19		CV 29		CV 50		CV 75		CV 112		CV 173		CV 190		CV 270 CV 280		CV 410 CV 435		CV 720		
			cl IV	cl VI	cl IV	cl VI	cl IV	cl VI	cl IV	cl VI	cl IV	cl VI	cl IV	cl VI	cl IV	cl VI	cl IV	cl VI	cl IV	cl VI	cl IV	cl VI	cl IV	cl VI	cl IV	cl VI	cl IV	cl VI	cl IV
AP23	0.3	3+15	14	18	14	18	9	12	5	8	3	4	2	3															
	0.4	6+18	16	22	16	22	11	17	7	10	4	5	3	4															
	0.6	6+30	22	28	22	28	16	25	10	15	6	8	4	6															
	1.5	15+60	45	60	45	60	35	56	27	33	15	17	8	12															
AP28	0.6	3+15	27	30	27	30	17	26	8	15	6	9	4	6															
	1.0	6+18	38	40	38	40	21	30	13	19	10	12	5	8															
	1.2	6+30	50	55	50	55	26	47	23	26	12	16	7	12															
	2.4	15+60	80	90	80	90	48	75	40	56	25	38	17	23															
AP34 / AP35	1.2	3+15	60	65	60	65	50	55	20	23	12	18	10	16	4	4	2	3	1	1									
	1.5	6+18	80	85	80	85	60	65	30	35	15	18	12	15	6	7	4	5	2	3									
	1.9	6+30	99	99	99	99	80	85	40	45	20	25	14	16	7	8	5	6	3	3									
	3.5	15+60							62	65	36	45	25	29	11	13	8	11	6	6									
AP43 / AP44	2.8	3+15									35	40	24	26	7	8	6	6	4	4									
	3.3	6+18									40	45	26	28	9	10	8	8	5	5									
	3.8	6+30									40	45	26	28	12	12	10	10	6	6									
	7.6	15+60									65	85	40	70	28	37	22	27	15	17									
AP47	7.6	15+60																			15	17							
AP45	7.6	15+60									65	85	40	70	28	37	22	27	15	17									
AP48	7.6	15+60																			15	17	7	8	5	6	3	4	
AP61	15.5	15+60															44	54	30	34	30	34	14	16	10	12			
AP63	15.5	15+60																									6	8	

cl. IV : tenuta classe IV - ANSI FCI 70.2 - IEC 60534-4

cl. VI : tenuta classe VI - ANSI FCI 70.2 - IEC 60534-4

NB. For class V use only 15+60 psi

DIMENSIONI

SIZE	A inches (mm)	B inches (mm)	G inches (mm)	C inches (mm) - Standard trim			C inches (mm) - Balanced trim		
				Std. bonnet	with bellows	Finned Extended	Std. bonnet	with bellows	Finned Extended
½"	8.0 (203)	1.9 (48)	4 (100)	5.1 (129)	9.0 (228)	6.8 (173)	—	—	—
¾"	8.1 (206)	2.3 (59)	4 (100)						
1"	8.3 (210)	2.4 (62)	4 (100)						
1" ½	9.9 (251)	3.1 (78)	4 (100)	5.0 (128)	8.9 (226)	7.3 (185)	3.2 (157)	10.1 (256)	8.4 (214)
2"	11.3 (286)	3.3 (83)	4 (100)						
3"	13.3 (337)	4.1 (105)	4 (100)	7.4 (187)	12.0 (306)	10.0 (260)	9.0 (230)	13.7 (348)	11.1 (282)
4"	15.5 (394)	5.4 (137)	4 (100)	7.2 (184)	12.1 (307)	12.2 (310)	9.6 (245)	14.4 (365)	12.2 (310)
6"	20.0 (508)	7.0 (178)	8,6 (220)	13.8 (178)	18.9 (480)	18.9 (480)	13.8 (351)	18.9 (480)	18.9 (480)
8"	24.0 (610)	8.3 (210)	8,6 (220)	15.5 (393)	22,5 (571)	19.8 (502)	14.7 (373)	22,5 (571)	19.8 (502)

ACTUATOR

TYPE	Ø D inches (mm)	E inches (mm)	F inches (mm)		THRUST AREA inches ² (cm ²)	THRUST VOLUME liter
			N.O.	N.C.		
AP23	9.05 (230)	9.64 (245)	5.3 (135)	3.4 (85)	31.46 (203)	~ 1.8
AP28	10.82 (275)	9.96 (253)			47.12 (304)	~ 3
AP34 AP35	13.46 (342)	10.86 (276)	7,3 (185)	3,4 (85)	73.62 (475)	~ 5.7
AP43 AP44	16.93 (430)	11.93 (303)	11,8 (300)	5,9 (150)	115.32 (744)	~ 11.5
AP45		15.47 (393)				
AP47		13.18 (335)	9,11,8 (300)	5,9 (150)		~ 13.5
AP48		22.44 (570)	16,9 (490)	16,9 (490)		
AP61	23.6 (600)	23.42 (595)	16,9 (490)	16,9 (490)	262.95 (1690)	~ 32
AP63	23.6 (600)	24.60 (625)	16,9 (490)	16,9 (490)	262.95 (1690)	~ 40

N.O. = Direct actuator - Normally Open Valve
 N.C. = Reverse Actuator - Normally Closed Valve

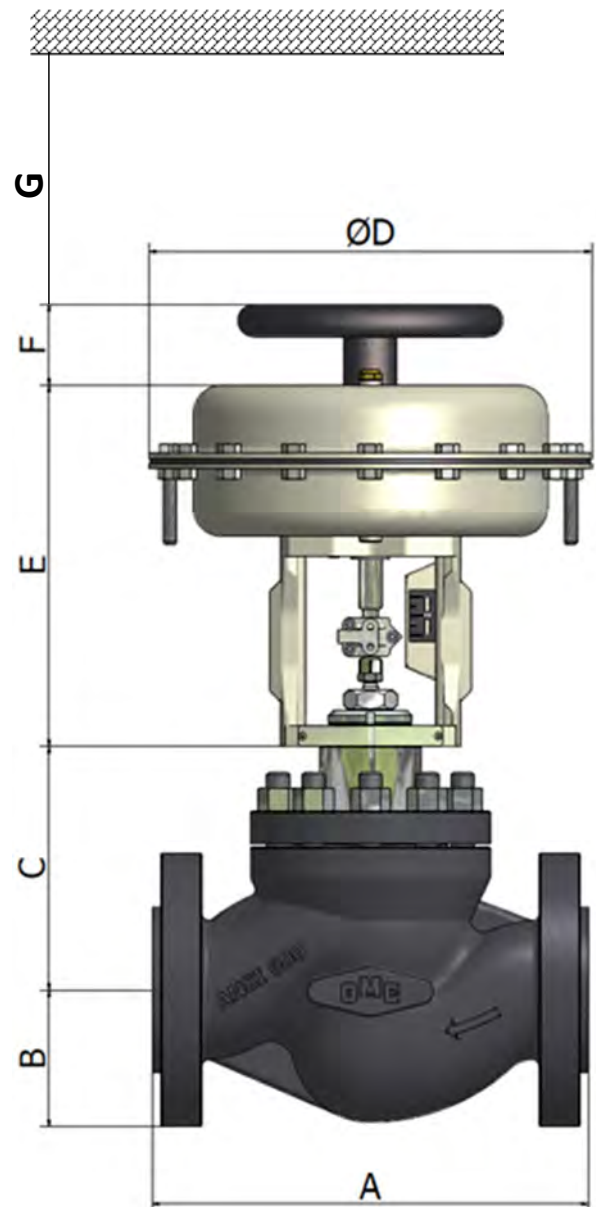

PNEUMATIC PISTON SERIES OP

The OP series pneumatic actuators are used especially for multi-spring piston valves with ON-OFF function. Available in 2 sizes, are extremely compact. Equipped with mechanical stroke indicator, the integral yoke meets Std CEI EN60534-6-1 to direct mounting accessories such as, switches, etc ...

TECHNICAL DATA

TYPE	Piston type - multispring
CONTROL SIGNAL	from 90 psi (6 bar) to 145 psi (10 bar)
MAX AIR SUPPLY PRESSURE	145 psi (10 bar)
PNEUMETIC CONNECTION	1/4" NPF-F
AMBIENT TEMPERATURE	-4÷160°F (-20+70°C)

MATERIALS

	STANDARD	ON REQUEST
CASING	Painted Alluminium	Electropolished Stainless Steel
YOKE	Painted Carbon steel	Electropolished Stainless Steel
BOLTS AND NUTS	A193 B7 - A194 2H	Other materials
PISTON	NBR	//
SPLINDE	ASTM 182 F304	//
VALVE CLAMP CONNECTION	ASTM A 351 CF8	//
SPRING	EN 10270-1SH painted	Stainless steel
INTERNAL PARTS	Zinc plated carbon steel	Stainless steel

PROTECTIVE COATING

STANDARD	Finish powder coat polyester RAL 7032
ON REQUEST	Painting for see environment Customer specification

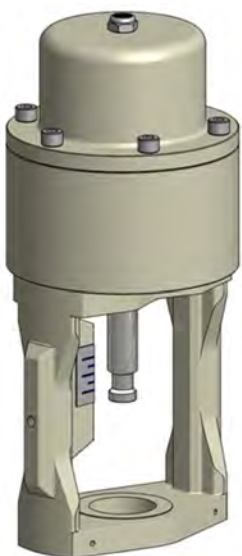

ACCESSORIES

- ◆ Alarm contacts
- ◆ Air filter regulator
- ◆ Solenoid valves
- ◆ Lock-Up pneumatic device

MAXIMUM ADMISSIBLE PRESSURE DROPS IN bar (FLUID OPEN) FOR UNBALANCED CONSTRUCTION

ACTUA-TOR	CV 6	CV 8	CV 13	CV 19	CV 29	CV 50	CV 73 5	CV 112	CV 173 CV190
OP10	12	12	12	12	12	12			
OP16							12	8	3

DIMENSIONS

SIZE	A inches (mm)	B inches (mm)	G inches (mm)	C minches (mm) - Standard trim			C inches (mm) - Balanced trim		
				Std. bonnet	with bellows	Finned Extended	Std. bonnet	with bellows	Finned Extended
½"	8.0 (203)	1.9 (48)	4 (100)	5.1 (129)	9.0 (228)	6.8 (173)	—	—	—
¾"	8.1 (206)	2.3 (59)					—	—	—
1"	8.3 (210)	2.4 (62)		—	—	—			
1" ½	9.9 (251)	3.1 (78)		5.0 (128)	8.9 (226)	7.3 (185)	3.2 (157)	10.1 (256)	8.4 (214)
2"	11.3 (286)	3.3 (83)		7.4 (187)	12.0 (306)	10.0 (260)	9.0 (230)	13.7 (348)	11.1 (282)
3"	13.3 (337)	4.1 (105)		7.2 (184)	12.1 (307)	12.2 (310)	9.6 (245)	14.4 (365)	12.2 (310)
4"	15.5 (394)	5.4 (137)							

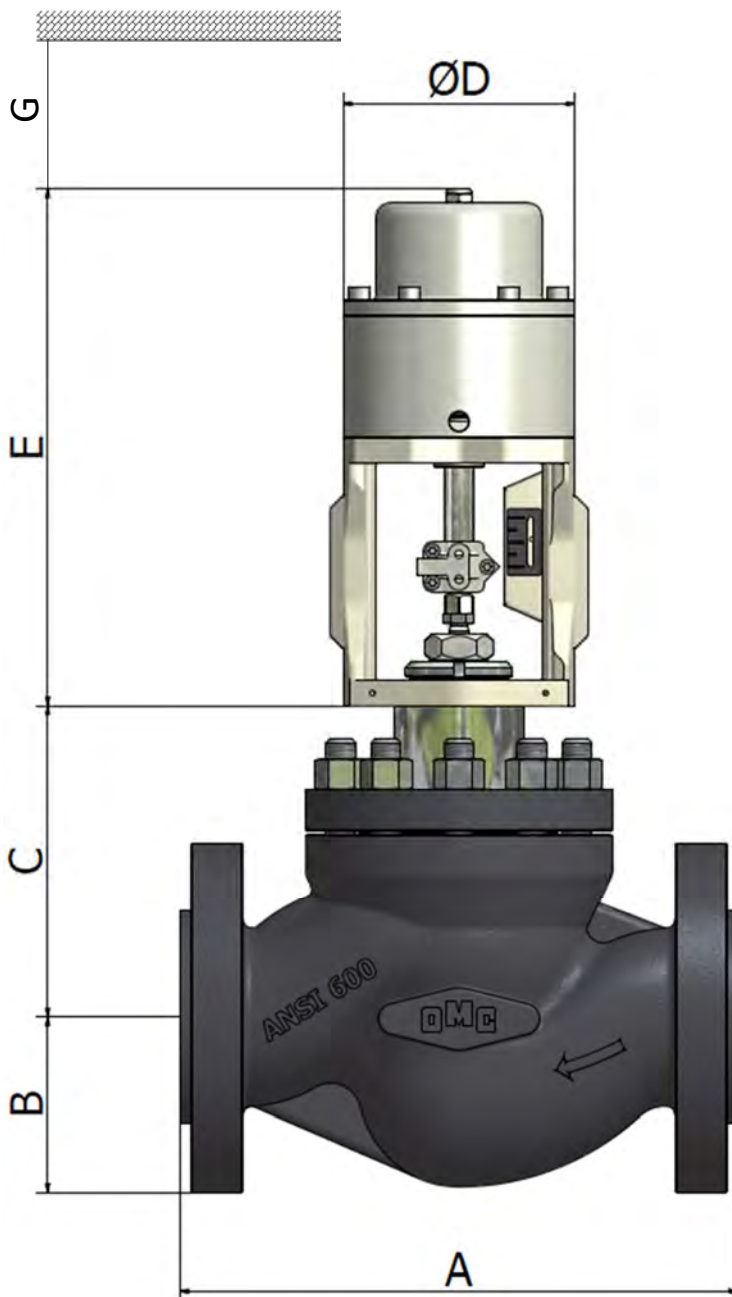

ACTUATOR				
TYPE	Ø D inches (mm)	E inches (mm)		
		½ - 1" ½	2"	3" - 4"
OP10	9.05 (230)	10.51 (267)	11.50 (292)	//
OP16	10.82 (275)	//	//	13.19 (335)

ELECTRIC ACTUATOR

The OMC control valves can be supplied with electric actuators of the best manufacturers to meet the most varied demands in the industrial processes.



AVAILABLE ENDS CONNECTIONS

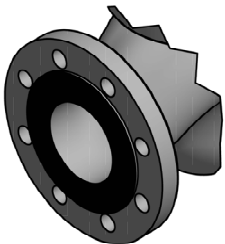

RAISED FACE

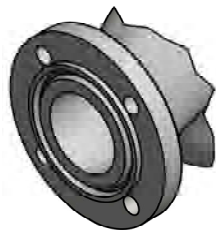

RING JOINT

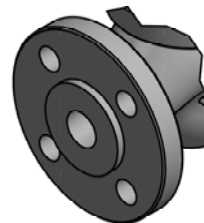

MASCHIO

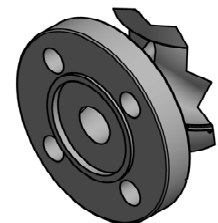

FEMMINA



FLAT FACE



BUTT-WELDING

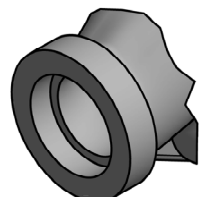

SOCKET-WELDING



SCANALATO

VALVE BODY WEIGHT (Kg)

SIZE	Standard	Finned / Extended	With bellows
½"	8.8	9.1	10.0
¾"	9.8	10.1	11.0
1"	10.5	11.0	11.6
1" ½	19.3	19.9	21.0
2"	23.3	23.9	25.0
3"	47.8	49.7	52.0
4"	84.6	88.2	88.5
6"	301.8	207.4	208.5
8"	368.4	374.1	375.2

PNEUMATIC ACTUATOR WEIGHT (Kg)

TYPE	SIGNAL	ACTUATOR	HAND WHEEL
AP23	3+15 / 6+18 / 6+30	7	1
	15+60	8	
AP28	3+15 / 6+18 / 6+30	9	
	15+60	10	
AP34 / AP35	3+15 / 6+18 / 6+30	15	2
	15+60	17	
AP43 / AP44	3+15 / 6+18 / 6+30	27	3
	15+60	32	7
AP45	15+60	38	7
AP47	15+60	45	7
AP48	15+60	58	21
AP61	15+60	168	21
AP63	15+60	182	21
OP10	ON-OFF	8	//
OP16	ON-OFF	13	//

The contents of this publication are presented for information purpose only. We reserve to modify or improve the designs or specifications of such products at any time without notice

