

MD HIGH RANGE PRESSURE SWITCHES

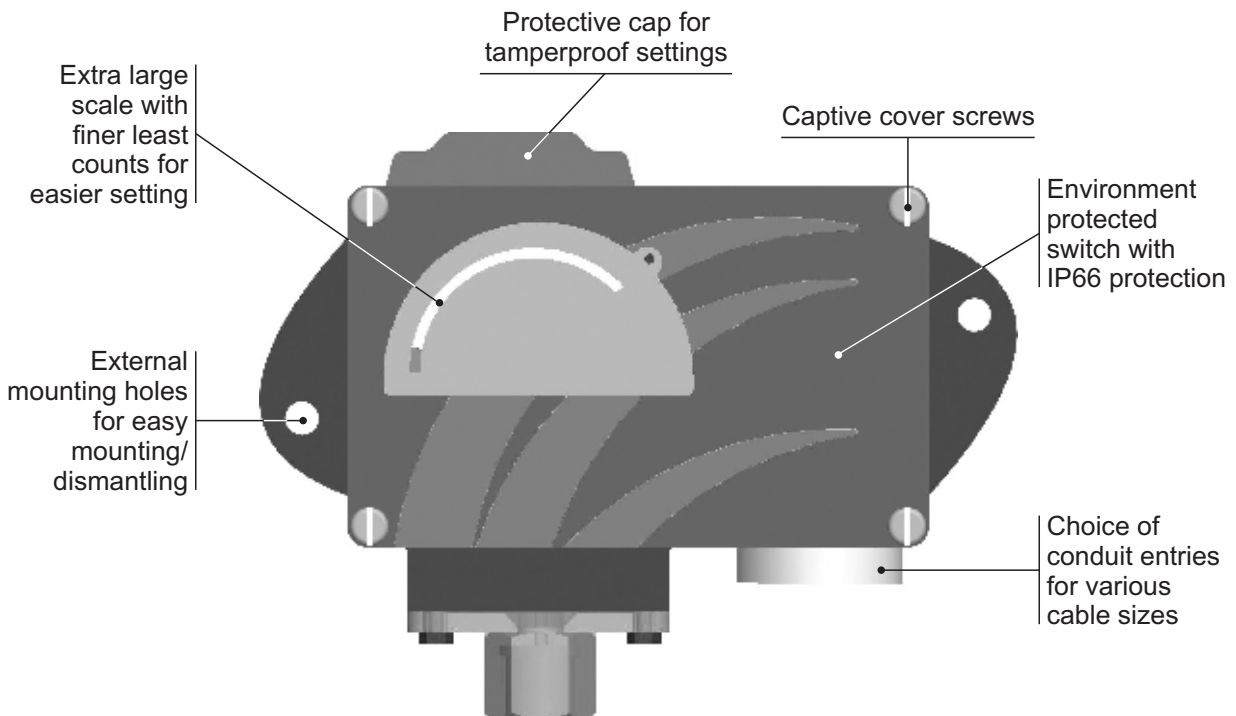
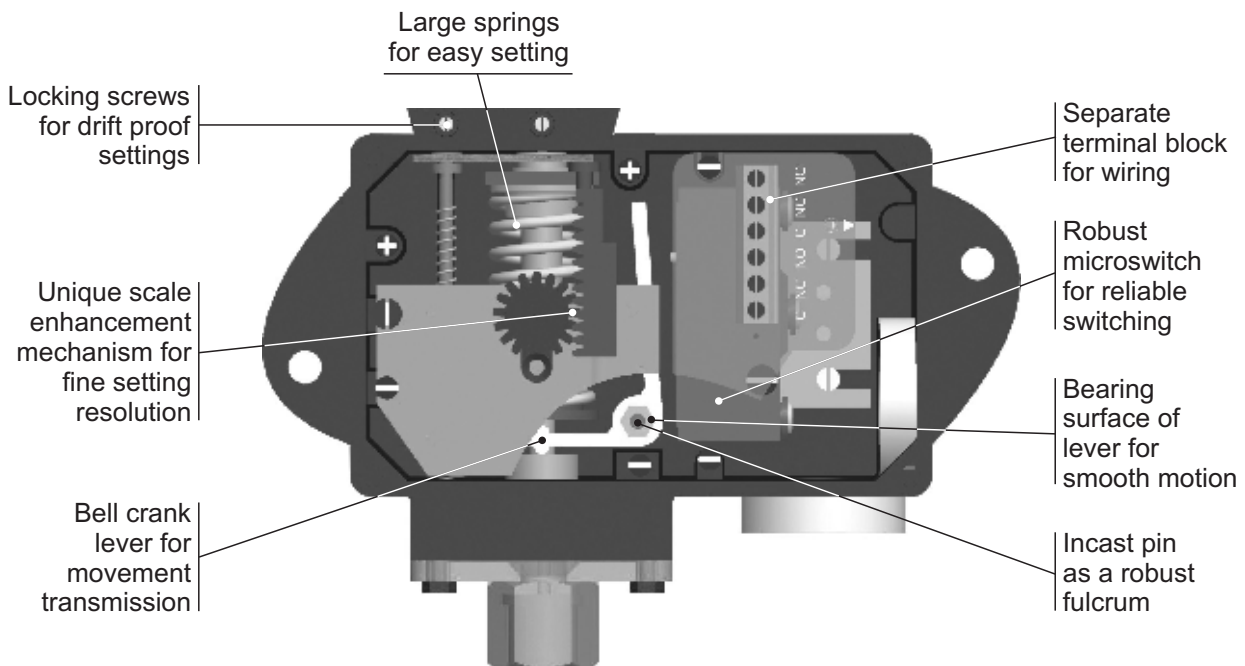

Approximate Weight : 0.700 Kg.

Some Applications : Used in non-hazardous areas.
For any type of corrosive and non-corrosive gases and fluids.

Electrical Connection :

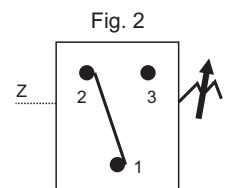

HIGH RANGE PRESSURE SWITCHES MD

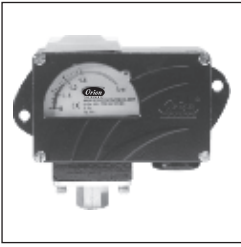

PRESSURE CAPSULE DETAILS

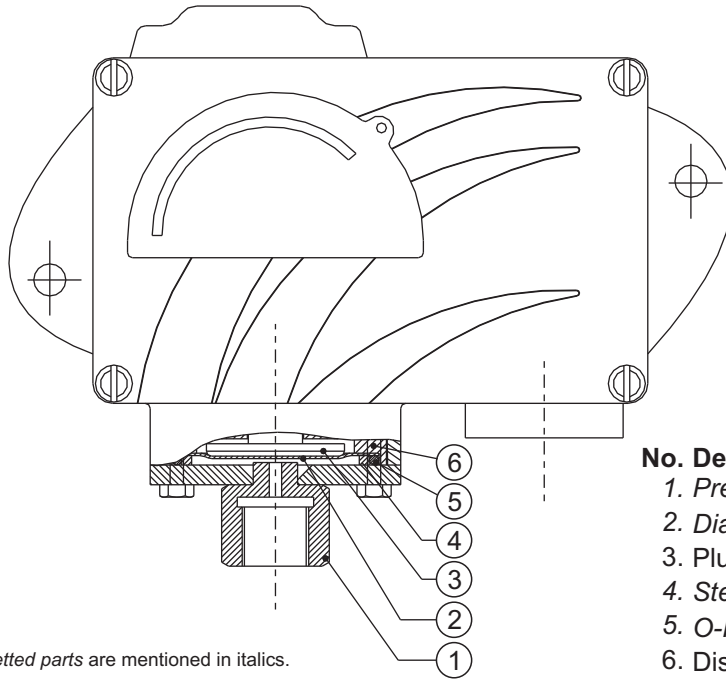

No. Description

1. Pressure Housing
2. Diaphragm (Teflon[®])
3. Plunger
4. Steel Ring (SS316)
5. O-Ring (Teflon[®])
6. Disc

Note : *wetted parts* are mentioned in italics.

INSTALLATION DRAWING

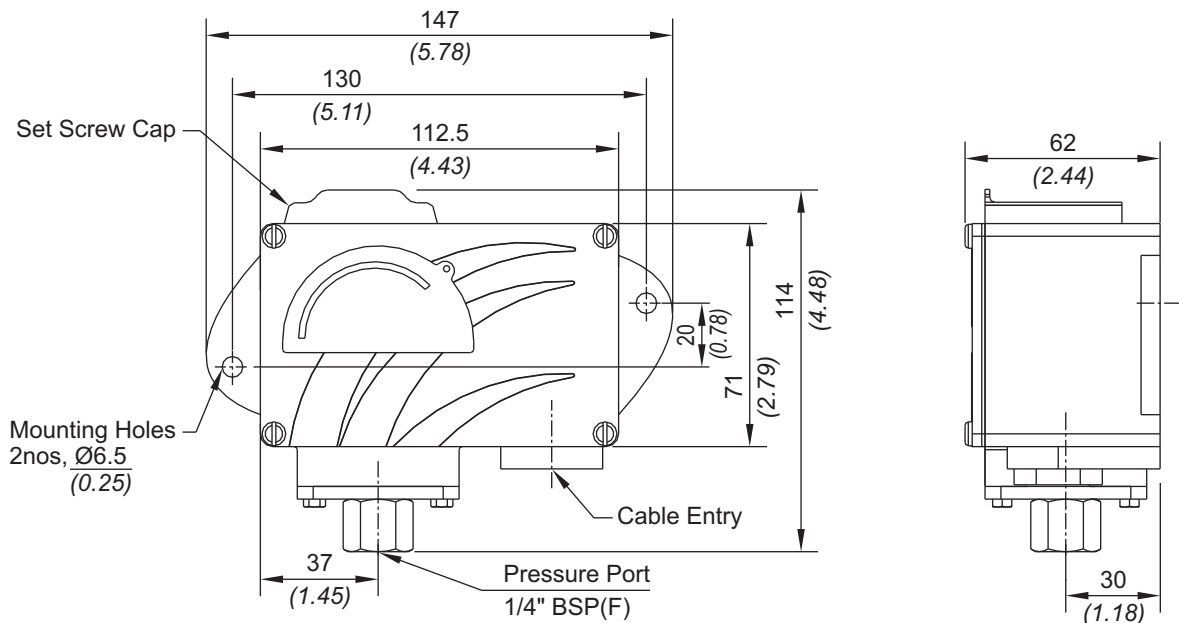

APPROX. DIMENSIONS IN $\frac{\text{mm}}{\text{inches}}$

MD HIGH RANGE PRESSURE SWITCHES

RANGE SELECTION TABLE

Range Code	Range bar (psi)	†Differential bar (psi)	Maximum Working Pressure bar (psi)
		Approximate Maximum for "A1" microswitch	
LP	0.067 - 0.213 (0.97 - 3.09)	0.02 (0.29)	5 (72.52)
LP5	0.1 - 0.5 (1.45 - 7.25)	0.08 (1.16)	5 (72.52)
H01	0.1 - 1.0 (1.45 - 14.50)	0.10 (1.45)	12 (174.05)
H02	0.1 - 1.5 (1.45 - 21.76)	0.12 (1.74)	12 (174.05)
H03	0.2 - 2.6 (2.90 - 37.71)	0.20 (2.90)	12 (174.05)
H04	0.2 - 3.6 (2.90 - 52.21)	0.20 (2.90)	12 (174.05)
H07	0.5 - 7.0 (7.25 - 101.50)	0.40 (5.80)	12 (174.05)
H10	0.5 - 10.0 (7.25 - 145.38)	0.40 (5.80)	25 (362.6)
H15	1.0 - 15.0 (14.5 - 217.56)	0.80 (11.60)	25 (362.6)
H30	5.0 - 25.0 (72.52 - 362.6)	0.80 (11.60)	35 (507.63)

† Minimum differential increases with setpoint, values with neoprene diaphragm (Graphs available on request)

*** Note :**

Microswitches A2 through A9 can be supplied in some ranges and differentials will vary with microswitch used. Please contact sales office for details. Please check availability of adjustable differential with sales office.

HOW TO ORDER INDUSTRIAL HIGH RANGE PRESSURE SWITCHES

Group 1	Group 2	Group 3	Group 4	Group 5	Group 6	Group 7	Group 8
Non standard allocation <input type="checkbox"/> Reserved for non-standard options not covered in catalogue. Will be given by manufacturer, only after agreement of supply details with customer.	Model MD = Industrial pressure switch with diecast Aluminium enclosure to IP66 as per IS2147	Cable Entry Size 1 = 1/2" NPT threads 2 = 3/4" NPT threads 3 = M20 X 1.5 threads	Switch Type PF1 = pressure switch, fixed differential without scale PF2 = pressure switch, fixed differential with scale in bar PF3 = pressure switch, fixed differential with scale in psi PA1 = pressure switch, adjustable differential without scale PA2 = pressure switch, adjustable differential with scale in bar PA3 = pressure switch, adjustable differential with scale in psi *Available with A9 (in group 6) only	Range Code (values in bar) LP = (0.067 - 0.213) LP5 = (0.1 - 0.5) H01 = (0.1 - 1.0) H02 = (0.1 - 1.5) H03 = (0.2 - 2.6) H04 = (0.2 - 3.6) H07 = (0.5 - 7.0) H10 = (0.5 - 10.0) H15 = (1.0 - 15.0) H30 = (5.0 - 25.0)	Microswitch Type A1 = General purpose microswitch rated at 15 A; 250 VAC A2 = Hermetically sealed for corrosive environments A3 = gold plated contacts for low voltage applications A4 = DPDT configuration A5 = for high DC ratings A7 = 2SPDT switching elements A9 = General purpose microswitch rated at 5 A; 250 VAC Please refer page no. 230 for more microswitch options * Please refer note under Range Selection Table	Pressure Port Material / Size S1 = SS316 / 1/4" BSP(F) S2 = SS316 / 1/4" NPT(F)	Diaphragm 0 = Neoprene 1 = Teflon 2 = SS 316L 3 = Hastelloy C 4 = Monel

eg. A high range weatherproof switch with 1/2" NPT cable entry in aluminium housing as 1SPDT pressure switch, fixed differential without scale, having 0.1 bar to 1 bar pressure range, with 15Amp. microswitch, SS316 pressure housing with 1/4" BSP port size & neoprene diaphragm shall be specified by

Group 1	Group 2	Group 3	Group 4	Group 5	Group 6	Group 7	Group 8
<input type="checkbox"/>	MD	1	PF1	H01	A1	S1	0

Please specify full model number to avoid ambiguity.

HIGH RANGE PRESSURE SWITCHES

MD