

CRANKCASE EXPLOSION

RELIEF VALVES

INTRODUCTION

To avoid a dangerous pressure rise and resultant damage in the event of an explosion occurring in the crankcase of the larger types of compression ignition engines, it is necessary to provide pressure relief valves of ample area. However unless such valves are provided with effective flame-traps, they may actually increase the danger to personnel, since explosions too weak to damage an unrelieved crankcase can produce a large emission of flame through unprotected relief valves.

Following upon the successful marketing by Pyropress of an earlier series of imperial Crankcase Explosion Relief Valves. This literature details the metric range of valves sizes from 80mm to 300mm.

As before this range of valves incorporates an internal, oil wetted, wire gauze flame-trap, which after thorough investigation and testing has been found to give the most efficient degree of flame arresting.

Suggestions that the internal flame trap may clog up in the course of time has in practice over the past 60 years has been disproved since it is found that (a) the normal operating temperatures at the point of valve installation are too low to carbonise the oil film, and (b) the effect of the oil splash over the gauze is to keep it continuously washed with clean oil.

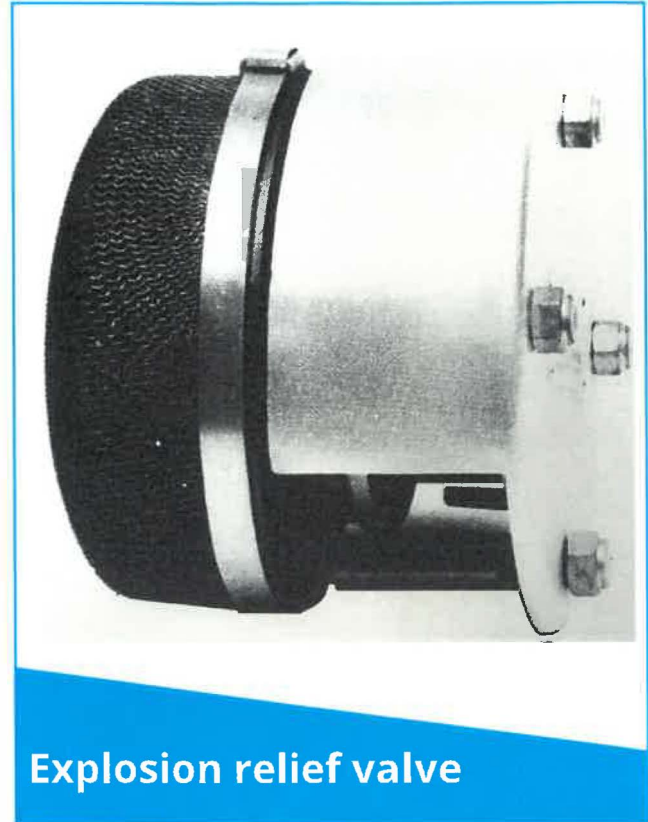

Explosion relief valve

This high efficiency flame-trap is combined with a quick acting, spring loaded, stemless relief valve, which ensures frictionless valve operation and eliminates any possible danger of sticking.

To complete this assembly a specially designed deflection cover is fitted which enable safe, directional control of the issuing gases.

By virtue of these important advantages the Pyropress Explosion Relief Valve gives greater protection from the effects of a crankcase explosion than other types hereto used.

FEATURES

✓ Metric range of valve from 80mm to 300mm

✓ Proven in service for long life and efficiency.

✓ Integral oil wetted flame trap providing instant quenching of flame in the event of an explosion.

✓ Safety deflecting cover.

TYPICAL ARRANGEMENT DRAWING FOR REFERENCE ONLY

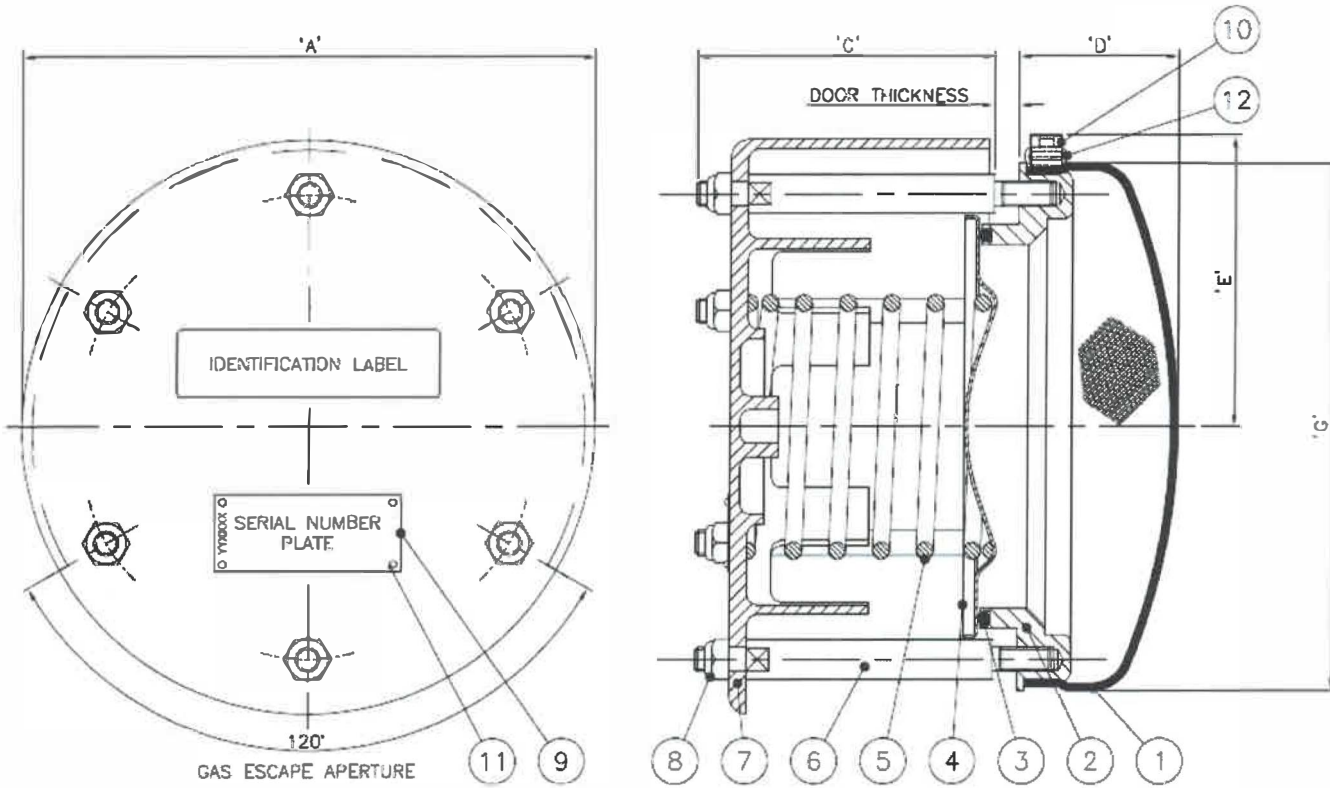

CUSTOMER INFORMATION

WHEN ORDERING, USE CODES 'MX1006/' OR 'MX1506/' FOLLOWED BY:

- WP FOR 0-2mm DOOR THICKNESSES.
- 1/WP FOR 3-6mm DOOR THICKNESSES.
- 2/WP FOR 7-10mm DOOR THICKNESSES.
- 3/WP FOR 11-14mm DOOR THICKNESSES.
- 4/WP FOR 15-18mm DOOR THICKNESSES.
- 5/WP FOR 19-22mm DOOR THICKNESSES.
- 6/WP FOR 23-26mm DOOR THICKNESSES.

PARTS LIST

ITEM	DESCRIPTION	QTY. PER VALVE	
		MX1006	MX1506
1	GAJZE ASSEMBLY	1	1
2	VALVE CARRIER	1	1
3	O-RING	1	1
4	VALVE	1	1
5	SPRING	1	1
6	VALVE GUIDE	4	6
7	COVER	1	1
8	NYLOC NUT	4	6
9	LABEL(SERIAL NUMBER PLATED)	1	1
10	CLIP	1	1
11	DRIVE SCREWS(SERIAL NUMBER PLATED)	4	4
12	BANDING	1	1

'G' HOLE DETAILS

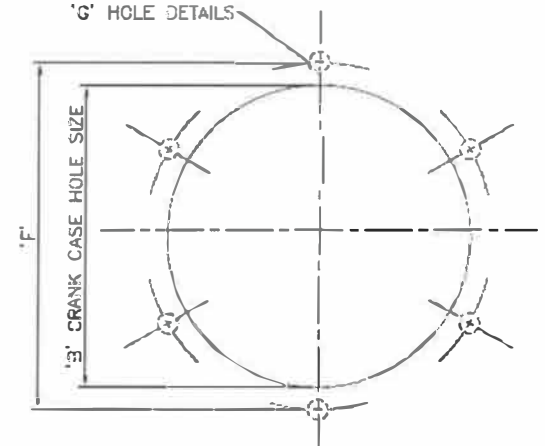

VALVE SPECIFICATION	ALL DIMENSIONS IN MILLIMETRES								VALVE AREA
	'A'	'B'	'C'	'D'	'E'	'F'	'G'	'H'	
MX1006	ø172	ø112	88	70	95	ø133.5	ø160	4 x M10	71 CM ²
MX1506	ø235	ø166	122	66	127	ø190.5	ø223	6 x M10	174 CM ²

DRAWING REF: 2033/A1 REV 1

TYPICAL ARRANGEMENT DRAWING FOR REFERENCE ONLY

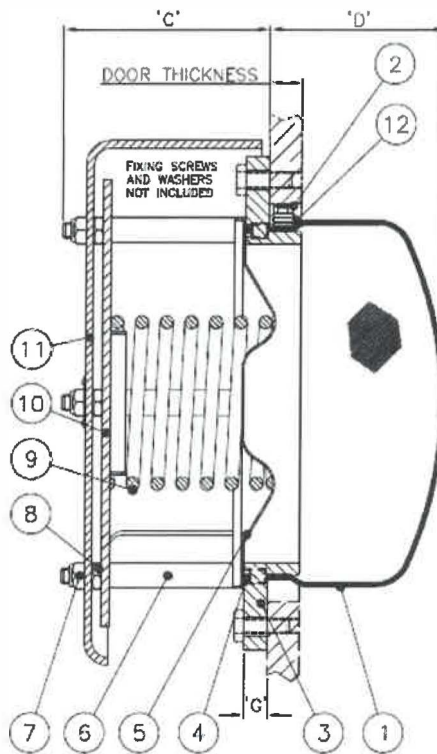
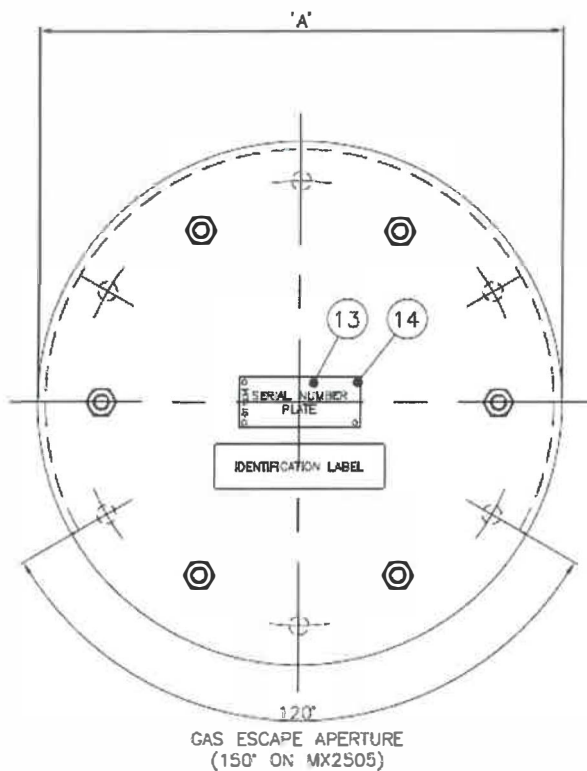

ITEM	DESCRIPTION	QTY. PER VALVE		
		MX2005	MX2505	MX3005
1	GAUZE ASSEMBLY	1	1	1
2	BUCKLE	1	1	1
3	VALVE CARRIER	1	1	1
4	O-RING	1	1	1
5	VALVE	1	1	1
6	VALVE GUIDE	6	6	6
7	NYLOC NUT	6	6	6
8	LOCK NUT	6	6	6
9	SPRING	1	1	1
10	SPRING RETAINING PLATE	1	1	1
11	COVER	1	1	1
12	BANDING	1	1	1
13	LABEL (GENERAL NUMBER PLATE)	1	1	1
14	DRIVE SCREWS (GENERAL NUMBER PLATE)	4	4	4

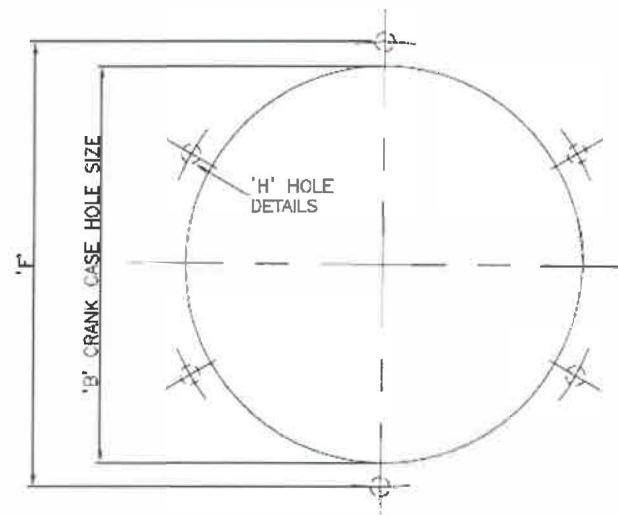

VALVE SPECIFICATION	ALL DIMENSIONS IN MILLIMETRES							VALVE AREA
	'A'	'g'	'c'	'D'	'F'	'G'	'H'	
MX2005	ø330	ø250	130	110	280	15	6 x ø12	314 CM ²
MX2505	ø385	ø300	160	120	330	15	6 x ø12	491 CM ²
MX3005	ø440	ø350	180	140	385	20	6 x ø14	706 CM ²

DRAWING REF: 2034/A1 REV 1

TECHNICAL SPECIFICATION

In other designs in which the flame-trap is placed on the outside of the relief valve, the flame is concentrated on a small area by the directive effect of the valve aperture when open, with subsequent destruction of the flame-trap.

The internal flame-trap avoids this effect due to the more even distribution of flow and so is capable of absorbing approximately three times as much heat.

It has been further demonstrated that the capacity of the internal flame-trap gauzes is roughly doubled by coating them in lubricating oil, as can be done by arranging them in the path of oil spray or splash from the large end bearings of the connecting rods or by supplying oil to them by alternative means.

The combination of these two features makes the internal, oil wetted, flame-trap about six times as effective as an external flame-trap.



Integral crankcase door can be fitted to customers requirements

As will be evident from the drawings these valves are available in five standard sizes.

All valves are set to operate between 0.08 and 0.2 bar opening pressure

Within certain limits special springs can be fitted to give opening pressures other than the standard quoted above

If required, valve lifting gear can be provided to enable periodic checks to be made on freedom of valve lift.

To enable these valves to be fitted to a wide range of engine sizes, it can be seen from the valve specification charts that various valve sizes are available in order to vent many sizes of crankcase. Additionally the variation in the depth of the flame-trap gauze assembly will accommodate most mechanical differences within the crankcase housing to prevent contact with any moving part.

IT MUST BE EMPHASIZED THAT THE DEGREE OF PROTECTION PROVIDED BY SUCH VALVES AND FLAME-TRAPS IN A CRANKCASE OF A GIVEN SIZE DEPENDS ON THE NUMBER AND SIZE OF VALVES FITTED AND THEIR RELATIVE LOCATION.

ORDERING PROCEDURE

- 1) When ordering a complete valve please state door thickness including gasket.
- 2) When ordering spares for the valves please state item number and description of parts required.

These explosion relief valves have been approved by the principal Marine Registration Societies

ABOUT PYROPRESS

Our products are designed to work in demanding and hazardous environments which require fast and cost effective solutions in instrumentation and control.

Pyropress control sensors provide safe and reliable electrical switching of alarm or control circuits in response to changes in temperature, pressure, differential pressure, vacuum, flow and level conditions.

QUALITY

To support the design of state of the art products the company has invested heavily in the latest CNC technology.

We are able to produce our own components to a high degree of accuracy assuring a reliable and consistent quality product.