

REHEATER MODEL 280

Main features

It is used to increase the temperature of the fluid that it's flowing through pipes. The operation is very simple. Steam is injected through the upper flange and it circulates through small holes in the nozzle.

It produces steam jets which pushes the fluid into a low pressure area and creates turbulences. Then, the liquid and steam are mixed, increasing the initial temperature (An increase in pressure is also achieved).

No moving parts, so it reduces noise and vibration. It has no maintenance.

Body PN16, maximum pressure of 16 bar to 200°C.

Materials

Body: Nodular GGG40.3 (standard)
Bronze RG10

Stainless Steel A351 CF3M

Nozzle: Bronze RG10 (standard)

Stainless Steel A351 CF3M

Monel

Connections

Standard Construction Flanges DIN PN16

Applications

Water heating to wash barrels, tanks, drums, ..., piping installation where you can find frost, breweries, dry cleaners, chemical industries, ...

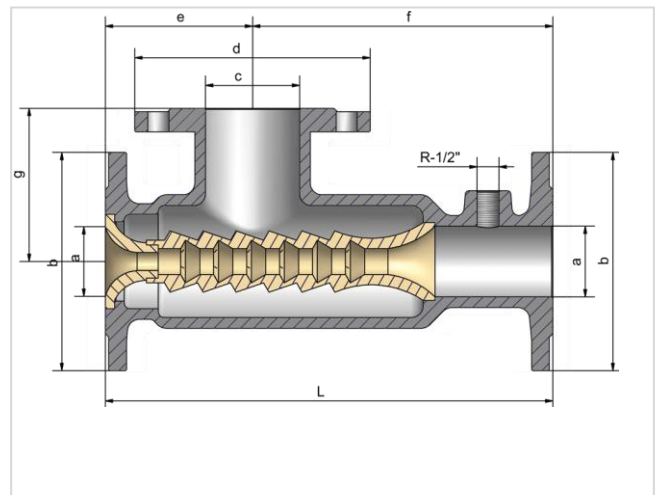
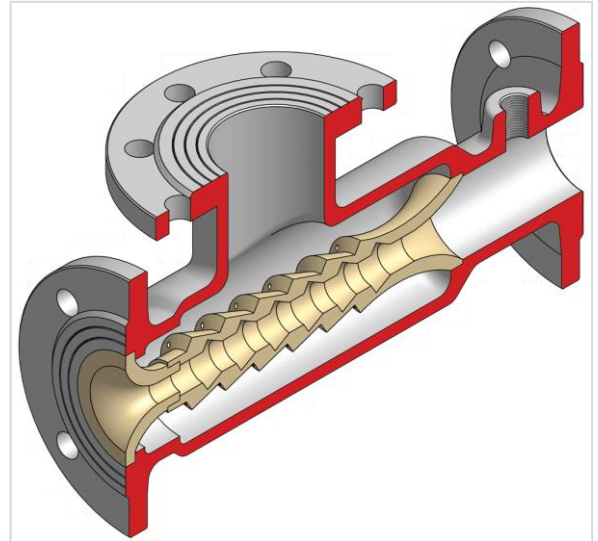

Test conditions:

Showed results of mixture are calculated working with saturated steam, inlet pressure of 4bar, and with input pressure of water or liquid to heat of 1bar and with an initial temperature of 15°C to 65-75°C.

Apart from heating the liquid, an increased output pressure of the device is achieved

Dimensions table

n°	MIX	a	b	c	d	e	f	g	L
0	1500	25	115	25	115	70	160	75	230
1	2500	25	115	32	140	85	180	90	265
2	4500	40	140	50	165	100	210	105	310
3	7000	50	165	65	185	110	240	120	350
4	10000	65	185	80	200	125	255	130	380
5	15000	65	185	100	220	140	285	140	425
6	20000	80	200	100	220	150	300	145	450
7	30000	100	220	125	250	150	320	153	470
	l/h	mm.							

a= inner diameter steam / outlet mixture (mm)
c= inner diameter suction liquid (mm)