

SELF-OPERATED PRESSURE REGULATORS

EXCESS PRESSURE VALVE MODEL **S2**

MAIN FEATURES

Self-actuating excess pressure valve. It's used to maintain the pressure upstream of the valve to an adjusted set point.

When upstream pressure rises above a set point, the valve opens proportionally pressure rising.

This series of regulators is suitable for steam, compressed air, gases and liquids.

Actuator mounts diaphragm with intermediate reinforced lining.

Set pressure regulating range between **0,02** and **10 barg** with different actuators (up 16 barg under request).

Condensation tank (pot) is available and necessary for steam or fluid upper to 125°C, to protect the diaphragm against overheating.

The excess pressure valve is not a safety valve, and then if necessary, an overpressure protection must be installed.

Max. permissible upstream pressure	10 barg (up to 16 barg, consult)
------------------------------------	----------------------------------

Sizes	DN15 to DN100
-------	---------------

Body material	Nodular Iron (GGG40.3) Bronze RG10 (consult) Carbon steel (GSC25N) Stainless steel (1.4408)
---------------	--

Connections	Flanged DIN PN16-PN40 Flanged ANSI 150 / 300 Threaded BSP / NPT, consult (up to 2")
-------------	---

Trim material	Stainless steel AISI 316L
---------------	---------------------------

Max. permissible temperature	NBR: -20 a 80°C EPDM: -40 a 125°C FKM: consultar PTFE: - 40 a 180°C
------------------------------	--

S2 valves are perfectly suitable for controlling gases in the temperature range between -10 and +80°C.



Common uses

It allows a zone with excess pressure to feed another minor, without the main line being depleted.

In case of excessive consumption prevents overpressures.

Special features

- Internal pressure intake can be replaced by external intake (mandatory for steam use).
- Stainless steel actuator.
- Reduced Kv
- Regulating protection cap (item 15)

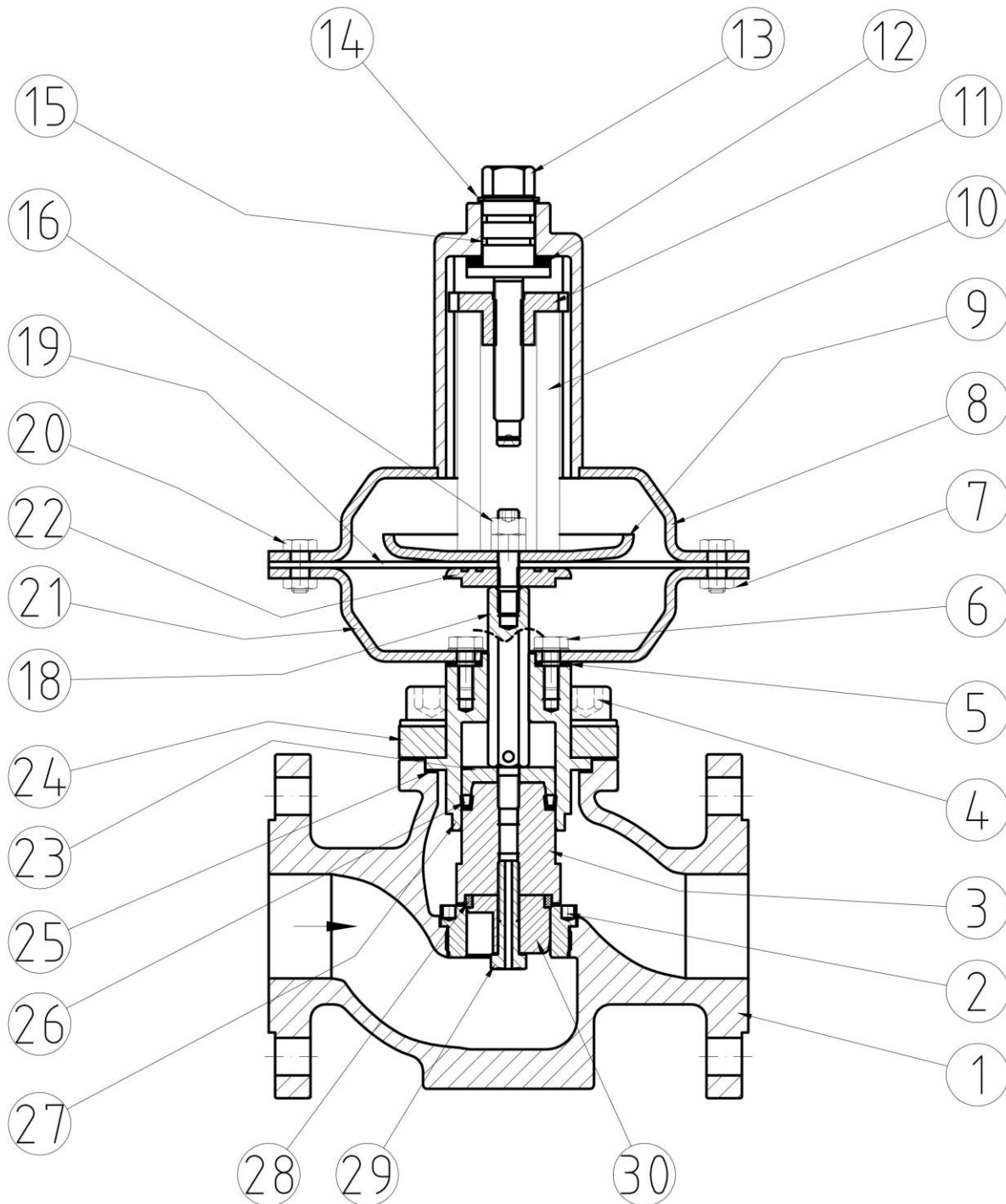

OPERATING

The excess pressure valves S2 model works with direct action principle.

The forces at the plug caused by the upstream and downstream pressures are eliminated by the balancing gasket. The plug is fully balanced.

When the force resulting from the upstream pressure p_1 , via internal control line (or external under consult) exceeds the spring force adjusted at the set point springs, the valve opens proportionally to the change in pressure.

The spring force is adjustable at the set point bolt (item 13).



	Description	Material		Description	Material
1	Body	Nodular EN-JS1049 (GGG40.3), Bronze RG10, Carbon steel WCB (1.0619), Stainless Steel 1.4408 (CF3M)	20	Bolt	Stainless steel A2-70
2	Seat	Stainless steel 1.4404 - SS 316L	21	Lower actuator	1.0335 (Sheet Steel with Epoxy painting) or Stainless steel AISI 316L
4	Bolt	8.8 / A2-70	22	Diaphragm plate	Stainless steel 1.4404 - SS 316L
5	Gasket	PTFE	23	Collar guide	Stainless steel 1.4404 - SS 316L
6	Bolt	Stainless steel A2-70	24	Cover	Galvanized steel 1.1141
7	Nut	Stainless steel A2-70	25	Gasket	Graphite
8	Upper actuator	1.0335 (Sheet Steel with Epoxy painting) or Stainless steel AISI 316L	26	Balancing collar	NBR / FKM / EPDM / PTFE + GR
9	Spring support	1.0035 sheet steel galvanized	27	Bush guide	Stainless steel 1.4404 - SS 316L
10	Regulation spring	Spring steel 52SiCrNi5 (epoxy)	28	Obturator	NBR / FKM / EPDM / PTFE + GR
11	Regulation nut	Galvanized steel 1.1141	29	Seal bolt	Stainless steel A2-70
12	Bearing	PTFE+GR	31	Seal support	Stainless steel 1.4404 - SS 316L
13	Regulation stem	Stainless steel 1.4404 - SS 316L			
14	Safety washer	Stainless steel A2-70			
15	O-ring	NBR / FKM / EPDM			
16	Nut	Stainless steel A2-70			
17	O-ring	NBR / FKM / EPDM	41	Lower stem bush	Stainless steel 1.4404 - SS 316L (DN100)
18	Stem	Stainless steel 1.4404 - SS 316L	42	O-ring	NBR / FKM / EPDM (DN100)
19	Diaphragm	NBR / EPDM / FKM	43	Washer spring	Stainless steel 1.4404 - SS 316L (DN100)
19	Diaphragm (optional)	PTFE	44	Bolt	Stainless steel A2-70 (DN100)
				Recommended spare parts	

Scheme for DN100

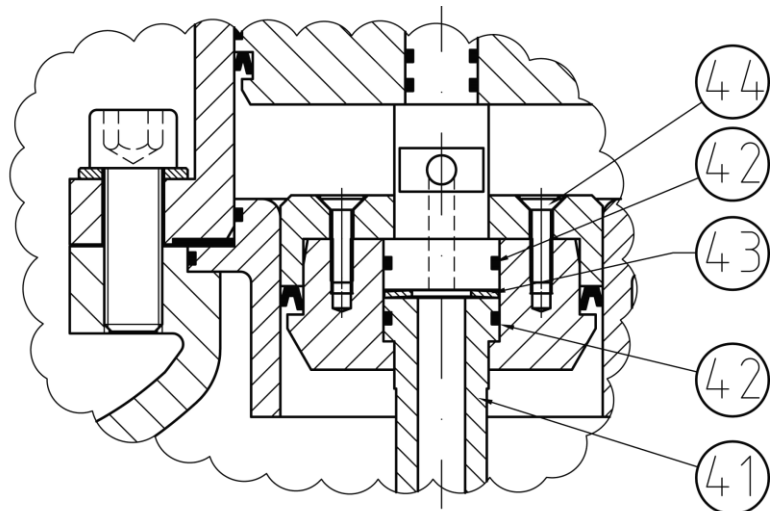



Dimensions

DN	15	20	25	32	40	50	65	80	100
Kv (m ³ /h)	3.5	5	9	13.5	22	32	57	82	115
A EN (mm)	130	150	160	180	200	230	290	310	350
A ANSI150 (mm) (inches)	-	-	184 7,25"	-	222 8,75"	254 10"	276 10,9"	298.5 11,75"	352.5 13,88"
A ANSI300 (mm) (inches)	-	-	197 7,76"	-	235 9,25"	267 10,51"	292 11,5"	317.5 12,50"	368 14,49"
L (mm)	345	345	320	320	375	375	405	490	505
L with cap (mm)	360	360	335	335	390	390	420	505	520
Weight (kg.)	20	20	22	23	25	28	43	53	60

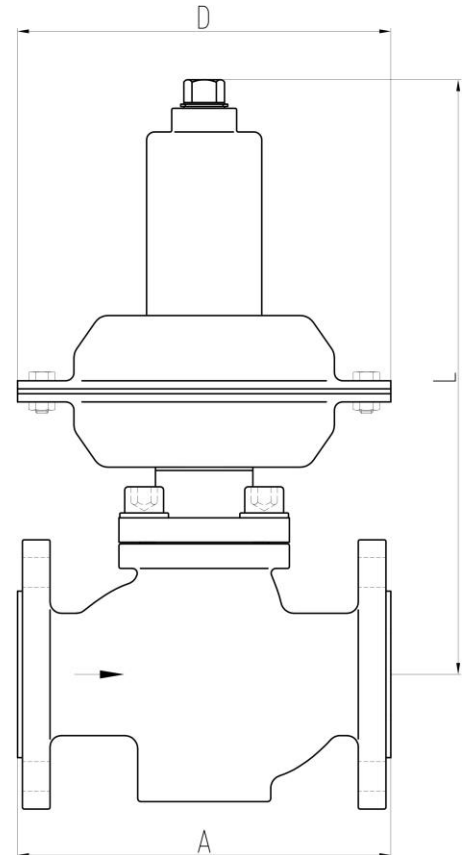

Approximate ranges of inlet pressure and actuator size (D)

Range (barg)	DN15 DN20	DN25 DN32	DN40 DN50	DN65	DN80	DN100
0,02 - 0,05	350	350	-	-	-	-
0,03 - 0,1	295	295	350	350	-	-
0,1 - 1	295	295	295	295	295	295
0,2 - 2	230	230	230	230	295	295
1,5 - 4	-	-	-	175	230	230
1 - 6	175	175	175	-	-	-
3 - 6	-	-	-	175	230	230
3 - 10	175	175	175	-	-	-
4 - 12	175	175	175	-	-	-

(When Kv reduced, use Kv selected to find correct actuator)

Technical data sheet

Nominal pressure	PN16-PN25-PN40 or CLASS 150-CLASS 300		
Diámetro Nominal	DN15 to DN50	DN65 to DN80	DN100
Differential pressure Maximum allowable Δp	16 bar	12 bar	10 bar
Maximum admissible body temperature	Ask for technical sheet HT-101		
Maximum admissible seal temperature	NBR: 80°C EPDM: 125°C FPM: 150°C PTFE+GR: 180°C		
Maximum admissible actuator temperature	Diaphragm NBR up to 80°C Diaphragm EPDM up to 125°C Diaphragm Viton up to 150°C Diaphragm EPDM or NBR+PTFE+tank up to 180°C		



THIS SHOULD NEVER BE USED AS SAFETY VALVE, ONLY LIKE ACCESSORY OF PRESSURE.

INSTALLATION

<p>Installation recommended according following details: 1.-Isolation Valve 2.-Filter 3.-Inlet pressure gauge 4.-Excess pressure Valve S2 7.-Condensing tank</p> <p>It is highly recommended to install a filter at the inlet of the excess pressure valve to avoid excessive maintenance of the compensation pipe.</p>	
<p>Scheme for gases and liquids.</p> <p>It is advisable to mount in horizontal pipes, with the actuator at the top, as shown in figure.</p>	
<p>Scheme for steam</p> <p>It must be requested with external pressure tap and condensation tank. The distance between the valve and the pressure intake point (upstream) must be approximately 1 meter (minimum 10xDN).</p>	